

# ULTRA VENDOR 32



**Polyvend**®  
INC

SERVICE MANUAL

**TABLE OF CONTENTS**

	PAGE
WARRANTY .....	A
GENERAL INFORMATION .....	1
SPECIFICATIONS .....	1
ELECTRICAL SPECIFICATIONS .....	1
INSTALLATION & SERVICE DOOR ADJUSTMENT .....	2-4
PRODUCT LOADING.. .....	5-6
SPECIAL PRODUCT LOADING .....	7
GUM AND MINT TRAY LOADING (NEW STYLE ASSEMBLY) .....	8-9
PRIMARY CABINET COMPONENT INFORMATION .....	10-11
ELECTRICAL SERVICE SECTION .....	12-13
DETAILED CONTROL BOARD OPERATION .....	14-15
SHIPPING POLICY .....	16-17
DRAWINGS AND PARTS LISTS .....	19
SLIDING DRAWER ASSEMBLY .....	20-21
SLIDING DRAWER ASSEMBLY ELECTRICAL .....	22-23
MAIN CABINET WIRING .....	24-25
SNACK TRAY ASSEMBLY 4-SELECTION (REMOVABLE DIVIDERS). .....	26A-27A
CANDY TRAY ASSEMBLY 8-SELECTION (REMOVABLE DIVIDERS) .....	28A-29A.....
SNACK TRAY ASSEMBLY 4-SELECTION (FIXED DIVIDERS) .....	26-27
CANDY TRAY ASSEMBLY 8-SELECTION (FIXED DIVIDERS). .....	28-29
MAIN CABINET ASSEMBLY .....	30-32
HELIX ASSEMBLY .....	33
SERVICE DOOR ASSEMBLY .....	34-35
PRODUCT DELIVERY COMPARTMENT ASSEMBLY .....	36-37
NEW STYLE GUM & MINT ASSEMBLY .....	38-39
POWER BOX ASSEMBLY .....	40-4 1
LIGHT FIXTURE .....	42
POWER BOX SCHEMATIC .....	44
COMPLETE ELECTRICAL MACHINE SCHEMATIC .....	45

WARRANTY  
LIMITED

Polyvend Inc. warrants this equipment to the ORIGINAL PURCHASER only, for a period of one (1) year from the date of shipment to be free from significant defects in material or workmanship, three (3) years on the control board, five (5) years on the vend motors to the extent such parts are warranted to Polyvend Inc., except for starters, light bulbs and fuses which will be warranted for two months from date of shipment.

Should any part prove defective within the warranted period, Polyvend Inc. will repair or replace (at its option) the defective component, but will not provide the labor, removal or reinstallation cost associated with such parts. All returned products or parts must be shipped freight prepaid to Polyvend and Polyvend will then prepay the shipping cost of the returned goods. Polyvend Inc. reserves the right to refuse any collect shipment. Any part returned under the terms of this warranty should be accompanied with a brief description of the defect or failure along with the model number and serial number.

This warranty applies only if the equipment is serviced and maintained in strict accordance with the instructions given in the Polyvend Service Manual, that no unauthorized repair or disassembly has been done. Any defect caused by improper source of power supplied, abuse of the product, accident, alteration, vandalism, mineral build-up or improper cleaning or service techniques will not be covered by warranty.

Polyvend service or repair to items not in warranty will be subject to the standard service charge for repair of the failed components. For warranty of service information call or write to Polyvend Service Department.

# POLYVEND ULTRAVENDOR 32

## GENERAL

The Polyvend Automatic Helix Merchandiser has independent dispensing units, with each helix activated by letter and number push buttons. The dispensing assemblies are snap-in hubs that can be installed from the front of the machine. This design provides easy access to displaying units on location. The pastry/snack selections are provided with a large helix of various pitches to accommodate a wide range of large products. There is also the option of a dual helix available for those desiring an alternative way to vend pastry and chip selections with various pitches to accommodate a wide range of large products. The candy helix dispensing units are also provided with a varied selection of helixes to accommodate a wide range of smaller products. Motors for all dispensing units are snap-in type for easy removal and reconfiguration of each tray assembly.

## SPECIFICATIONS

HEIGHT ..... 72"  
 WIDTH ..... 31 1/2"  
 DEPTH ..... 28 1/2"  
 SHIPPING WEIGHT ..... (approx.) 520 lbs.

### STANDARD CONFIGURATION

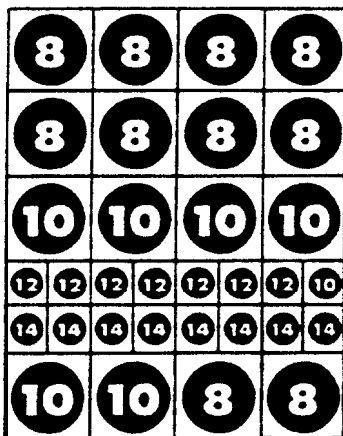

Capacity 346

### Product Size Capability

	COUNT	PRODUCT THICKNESS
<b>Snack Helix</b>	10	1 1/2"
	8	1 7/8"
<b>Candy Helix</b>	14	1"
	12	1 1/4"
	10	1 1/2"

\*\*Subject to change without notice.

## ELECTRICAL

PRIMARY VOLTAGE ..... 11 0VAC  
 SECONDARY VOLTAGE ..... 10.8/24VAC  
 MAX. CURRENT ..... .3AMP  
 VOLTAGE TO CHANGER ..... 24VAC  
 VOLTAGE TO BILL VALIDATOR ..... 24VAC



**CAUTION:** DISCONNECT POWER TO THE VENDING MACHINE BEFORE REMOVING THE CONTROL BOARD, COIN CHANGER OR VALIDATOR OR WORKING ON ANY ELECTRICAL COMPONENTS IN THE MACHINE.

## **INSTALLATION**

- \* Remove all external packing material
- \* Inspect equipment for shipping damage, if evident file claim immediately with the carrier (See shipping procedures).
- \* Remove keys from product dispensing compartment (in small manila envelope), unlock the service door and remove the shipping cardboard.
- \* Save extra fuses, etc. found in envelope as spare parts.
- \* Check the operation of the service door and locking mechanism. They should operate smoothly and latch at all three locking plates.
- \* Place machine into position and adjust leveling legs so the machine is level and all the legs sit firmly on the floor.
- \* Cut the plastic ties holding each tray in position.
- \* Plug service cord into 110VAC source using the three prong grounded plug provided. If a grounded outlet is not available, use a proper external ground on all locations.

**NOTE:** In order to comply with electrical safety regulations and Underwriters Laboratories requirements, all electrical equipment must be properly polarized and grounded. The Polyvend machine is wired so that it is properly polarized in accordance with the electrical code. If the wall outlet is wired and grounded properly, then the vending machine will connect properly.

Shown in views A and B are two properly grounded and polarized wall outlets. One is a three wire grounded type wall outlet (See View A) and the other is a two wire wall outlet (See View B) with an adapter in place.

Should the polarity at the wall outlet appear any way other than that shown below, the outlet should be rewired by qualified personnel.

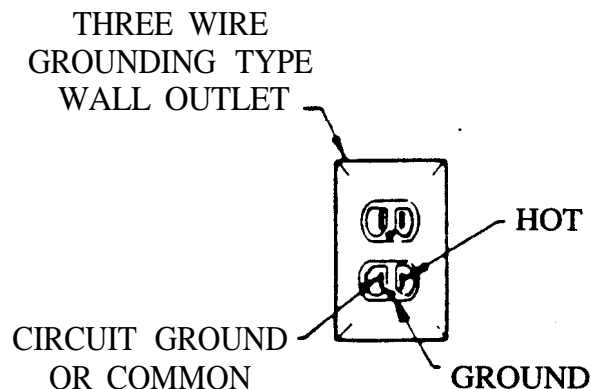

**VIEW A**

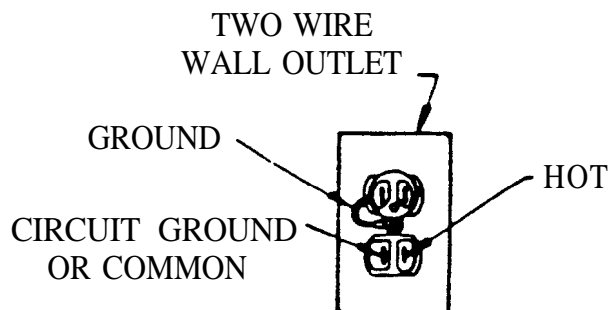

**VIEW B**

**CAUTION:** DISCONNECT POWER TO THE VENDING MACHINE BEFORE REMOVING THE CONTROL BOARD, COIN CHANGER OR WORKING ON ANY ELECTRICAL COMPONENTS IN THE MACHINE.

- \* Check to ensure that power is present. ‘Remember when you pull out the sliding drawer, the safety interlock will shut off the power to the control board. To re-energize the control board, pull the plunger out on the safety interlock switch located at the back of the pull out drawer. For the location of safety interlock (See figure 4 on page 10).
- \* Test the coin mechanism and coin return assembly to insure smooth operation. If the operation is not smooth, check to make sure that you have proper alignment of the changer with the coin return lever.
- \* Load the coin tubes on the coin changer located in the pull out sliding drawer. It is very important to fill the 25c 10c and 5c tubes for proper changer payback.  
**Note:** The maximum amount of change a Coinco 9302LF changer will hold is \$38.60; \$23 .00 in quarters, \$12.70 in dimes and \$3.40 in nickels. The maximum amount of change that a Mars TRC 6010XV will hold is \$29.95; \$16.75 in quarters, \$9.80 in dimes and \$3.40 in nickels.

- \* Operate each dispenser, using coins. Operation should be smooth. Remember; the safety interlock must be energized in order to test out the changer. To energize, pull out the plunger on the safety interlock switch located at the back of the pull out drawer (See figure 4 on page 10).
- \* Load the machine with product (See section on product loading).
- \* Place the price stickers on the trays to the right of the selection stickers. Set the prices of the products (See price setting).  
**Note:** To set the prices, the safety interlock switch must be energized by pulling the plunger out located on the switch at the back of the pull out drawer.
- \* Check to make sure that the Vend Options: forced vend and changer mode; are at the desired setting (See detailed control board operation).

SERVICE DOOR ADJUSTMENT SPEC.

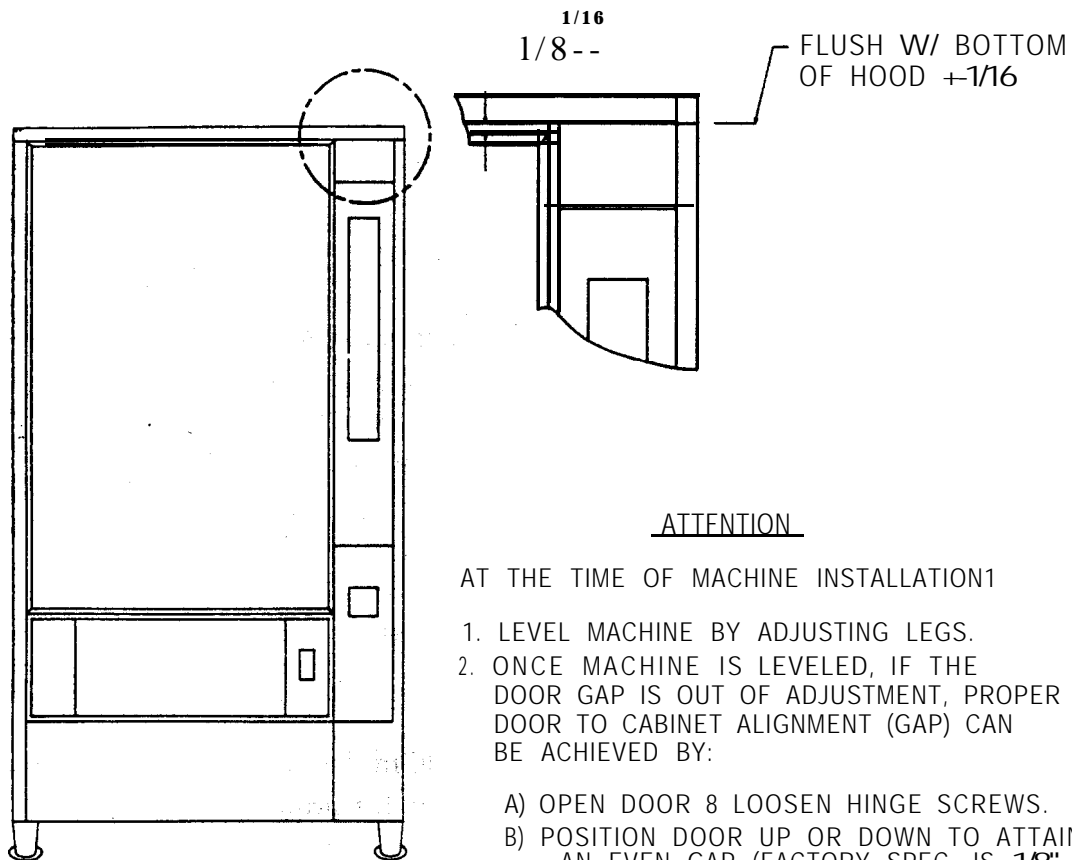

ATTENTION

AT THE TIME OF MACHINE INSTALLATION1

1. LEVEL MACHINE BY ADJUSTING LEGS.
2. ONCE MACHINE IS LEVELED, IF THE DOOR GAP IS OUT OF ADJUSTMENT, PROPER DOOR TO CABINET ALIGNMENT (GAP) CAN BE ACHIEVED BY:
  - A) OPEN DOOR & LOOSEN HINGE SCREWS.
  - B) POSITION DOOR UP OR DOWN TO ATTAIN AN EVEN GAP (FACTORY SPEC. IS 1/8" FROM BOTTOM OF HOOD ON CABINET TO TOP OF DOOR.)
  - C) RE-TIGHTEN SCREWS IN TOP, MIDDLE & BOTTOM SEQUENCE.

**PRODUCT LOADING**

**~HELIX TRAY DISPENSER**

There are several helix pitches available. To insure proper operation and maximum capacity, the product size should closely match the opening between the winding of the helix. The product should fit between the windings of the helix so as not to be tight, but should fill most of the opening.

The helix sizes available are listed below

Snack Helix	Product Thickness
10 count	1 1/2"
8 count	1 7/8"
6 count (optional)	2 1/2"
Candy Helix	Product Thickness
14 count	1"
12 count	1 1/4"
10 count	1 1/2"

**NOTE:** Because of the wiring configuration of this machine the candy rows must be rows C and D.

**~PRODUCT LOADING**

To load a tray, lift up on the tray front and slide the tray out of the machine until it comes to the tray stop. Then let the tray front tilt down into the loading position.

At this point, check that each helix is in its proper position. The figure 1 below shows the proper position.

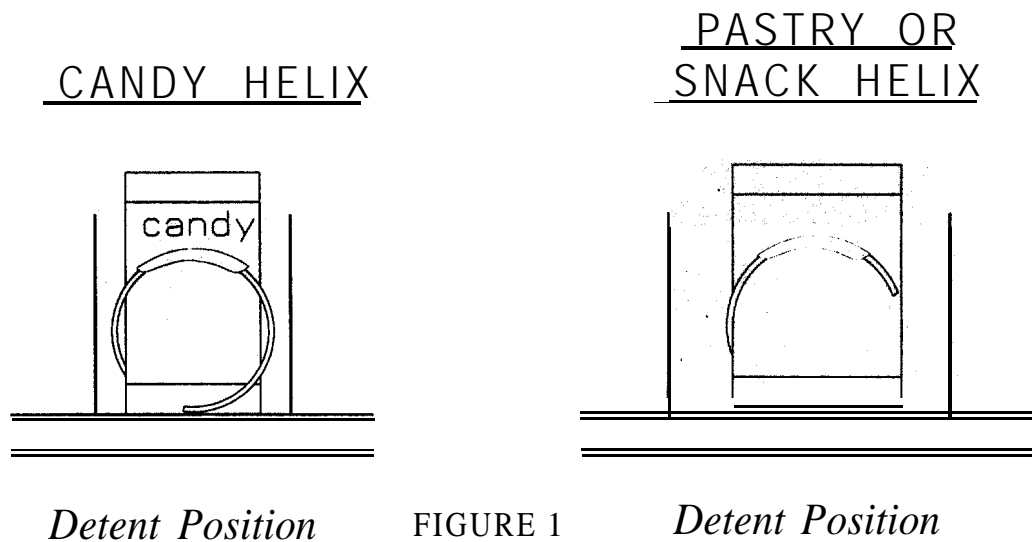



Starting at the front of the tray, insert a product between each winding of the helix so that the name of the product is displayed forward. Be sure to place the product all the way to the bottom of the tray and tilt free end at top backwards. Fill from front to back and be sure not to miss any positions. Note: Product must rest on tray NOT on helix. After filling the tray, lift the front of the tray and push it back in until the tray locks into place. Check that the tray is fully latched in place by pulling forward on the tray and ensuring that the tray does not advance beyond the latch.

## SPECIAL PRODUCT LOADING

### NARROW PRODUCT LOADING

In order to keep narrow products positioned properly the use of one of the spacer guides may be required. For additional guides order part no. 23170.

To install the guide, press on to the tray divider as shown in Figure 2 below.

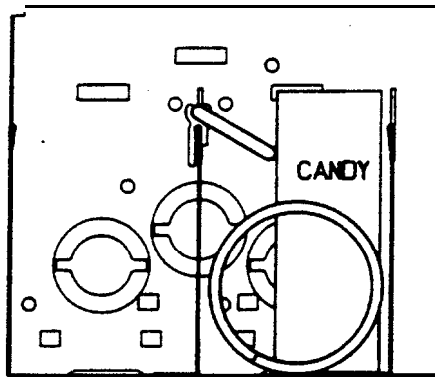

FIGURE 2

### FLAT OR SEMI-FLAT BOTTOM PRODUCT LOADING INSTRUCTIONS

Note: Instructions apply to candy tray only.

Certain candies and cigarettes have a flat or semi-flat bottom which is thick and wide. Polyvend Inc. has designed into our helix the flexibility to be 100% sure of the vending of this type of product. By moving the position of the helix, and thus the helix kicker 90 degrees, the best dispensing for boxed products is insured. You simply unlock the helix by pulling helix out of position. Turn the helix counterclockwise 95 to 100 degrees, then engage and push helix in, to lock in place. The helix should then be in the position shown below in Figure 3.

### CANDY HELIX

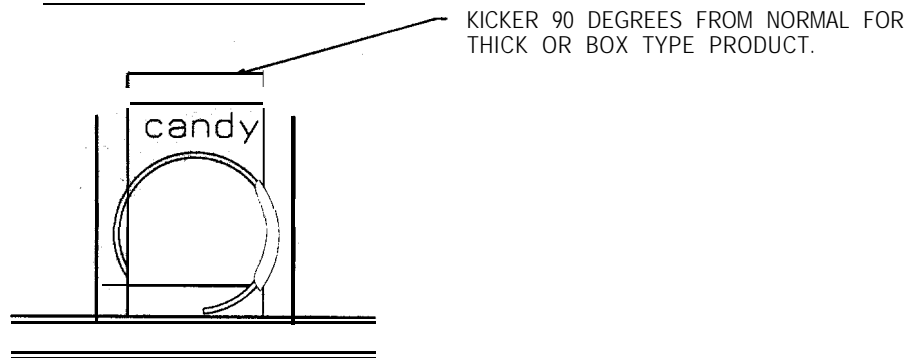

FIGURE 3



---

## **(OPTIONAL) GUM AND MINT TRAY LOADING NEW STYLE SLIDE OUT DRAWER ASSEMBLY**

The four select gum and mint dispenser is available in kit form or can be factory installed. All machines are prewired from the factory so you can install the gum and mint kit at a later date. The harness for the gum and mint assembly plugs into the motor distribution board. This is the same board that the tray harness plugs into. Each selection will hold up to 15 packs of gum (5 sticks per package) or roll candy up to 4 inches in length.

If a small diameter product of the anti-acid or breath mint type is to be vended it will be necessary to use a pair of height adapters for each selection. These height adapters can be ordered from your local distributor or from the Polyvend Parts Department. There are two different heights available, the thinner adapter is normally used for anti-acid or breath mints. The thicker adapter is used for very small diameter products or in some cases very short rolls or packages of candy or gum. The short product will then go in between the height adapters and act as a guide to keep them in position.

Each gum and mint assembly uses dividers that can be adjusted for the length of the product to be vended. They can be moved by pushing the divider towards the rear of the machine, unhooking the locking tabs and lift the divider upward. Move the divider closer or farther apart depending on the length of the product to be vended. To lock the divider in place allow the locking tabs on the divider to slip in the holes provided in the bottom of the tray and pull the divider towards the front of the machine locking it in place.

**NOTE:** New style gum and mint units installed in machines with serial number 18 11 and higher.



## LOADING INSTRUCTIONS

Take hold of the gum and mint assembly and pull the unit forward until the tray comes to the stop. To load, push the cover toward the rear of the machine. Lay the gum or mint packs on their side with the label facing toward the front of the gum and mint assembly.

Each selection has a clear, hinged product ejector which may require adjustment for each type of product. To adjust this ejector, on each side is a small compression clip. Squeeze the clips on each side (See figure below), then slide the ejector in or out until the hinge knuckles are located entirely behind the first product and directly above the second product. Release the clips and ensure that the ejector is locked into place.

**IMPORTANT:** Before sliding the tray assembly back into the machine, pull the cover forward over the product and under the retaining clips. Verify that both latches on the gum and mint assembly are engaged after the tray is pushed back into dispensing position.

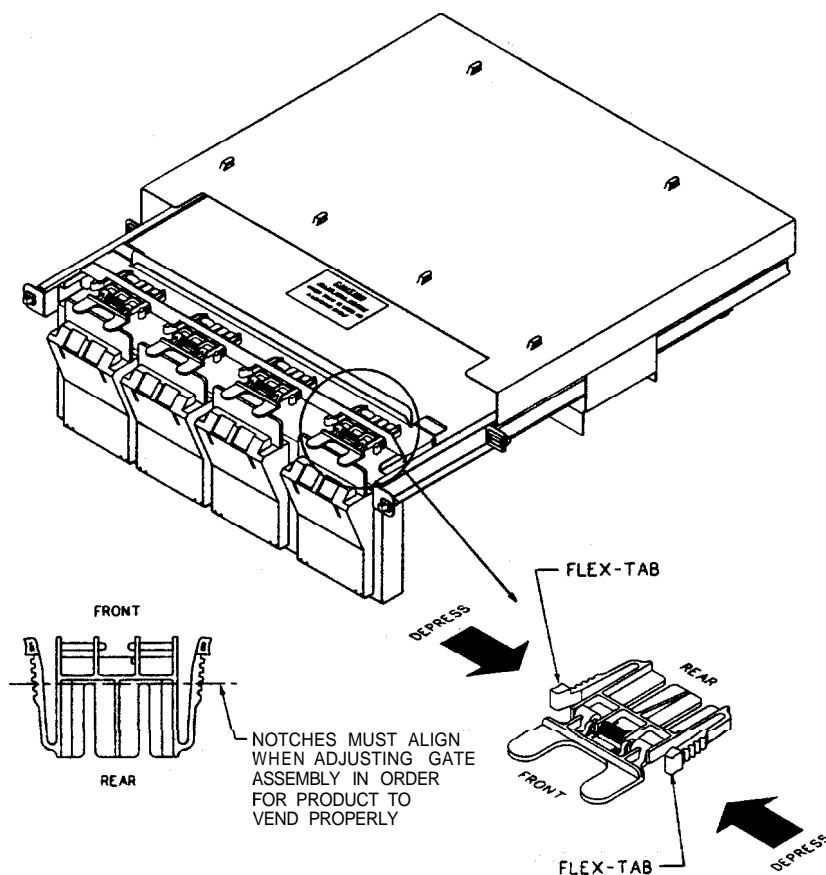

## GATE ADJUSTMENT

To adjust gate assembly front to rear depress flex-tabs as shown. Adjust gate assembly all the way forward until gate hinge is directly over the second item to be vended. Adjust gate assembly to the rear for larger product.



## PRIMARY CABINET COMPONENT INFORMATION

### SLIDEOUT CONTROL DRAWER

All electrical components in this compartment are low voltage. Located in this panel are the validator, the changer, control board (digital readout mounted on control board), 10 volt and 24 volt fuses and the motor distribution board. The 110 VAC transformer, light ballast and 110 volt circuit breaker are located in the high voltage electrical box mounted beside the coin bank. Starter for light is mounted on the right end of the light fixture.

Note: The safety interlock switch that turns on the power to the drawer is located in the rear, as shown in figure 4.

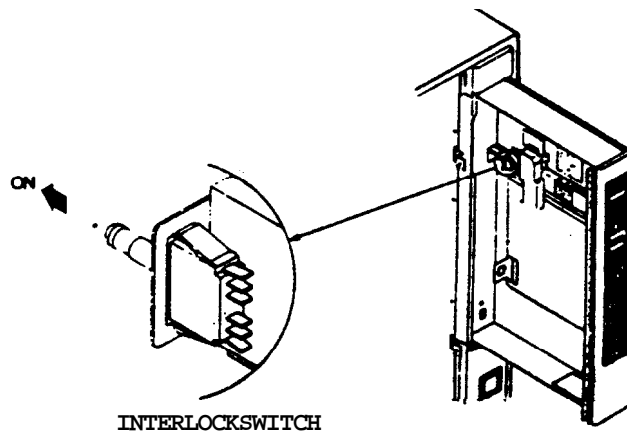

FIGURE 4

### REMOVAL OF SLIDEOUT CONTROL DRAWER

With the service door open, pull the slideout drawer out to the stop. Reach up from the storage area to the rear of the slideout drawer and unplug the harness connection from the rear of the drawer. **Note:** The slideout drawer may have to be pushed partially closed, in order to reach the back of the drawer and disconnect the wiring harness. Disconnect the six tray harness from the motor distribution board. After disconnecting the harness, pull the drawer to full open position. Remove the four (4) screws from the slide in the center of the drawer. Two of the screws must be removed through the large hole in the center of the slide section. Be careful and **DO NOT ALLOW THE DRAWER TO FALL** when removing these screws. Tilt the drawer out until you can reach the screw mounting the grounding wire and remove the screw. Lift and remove the drawer from the guides. For installation of the drawer reverse the procedure.

## **HIGH VOLTAGE POWER SUPPLY**

The high voltage power supply is located in the bottom of the machine, on the right hand side beside the coin bank. The circuit breaker for the 110 volt circuits is located on the top of the power supply. Also located inside the power supply are the ballast for the fluorescent light, the step down transformer and the RFI filter. The starter for the fluorescent light is located on the right end of the light fixture.

## **STORAGE COMPARTMENT**

The storage compartment is below the product display area and is accessed by opening the front door. Additional products may be stored in this area. Be sure to leave room for the delivery compartment when using the storage area.

## **HELIX TRAY REMOVAL**

Lift up on the front of the tray and pull the tray out to the stop. Allow the tray to tilt down into the loading position. Unplug the tray harness from the motor distribution board (located in the sliding drawer assembly) and set the harness on the tray you are removing. Lift up on the tray front and pull the tray upward and outward. The tray can now be removed from the machine for cleaning or service, To install the tray lift up on the front of tray so that the back of the tray is lower than the front and slide the tray in. Reconnect the tray harness in the drawer assembly.

**NOTE:** Because of the wiring configuration of this machine the candy rows must be rows C and D.

## **TRAY HELIX REMOVAL**

An individual helix can be removed for cleaning, repair or replacement with a different pitch whether the tray is in or out of the machine. A helix used with the new snap-in hub feature can be removed by first grasping the helix close to the hub and pulling firmly on the assembly toward the front of the tray.

To re-install the helix assembly, note that the snap-in shaft is square shaped, so the helix must be properly positioned (product kicker in correct position). With the helix correctly positioned, align the shaft of the hub with the octagon shaped motor drive and push the helix into place. A positive lock in position will be felt when the shaft is properly inserted and locked into place.

## ELECTRICAL SERVICE SECTION

### MODES OF OPERATION

The system will operate in one of two modes, sales or service. On power up (after completing configuration), the machine is in the sales mode. Service mode may be selected by pressing the mode switch mounted on the control board. The system will return to the sales mode if the mode switch is pressed or after 25 seconds of no service mode activity.

### SALES MODE

In the sales mode, the control board will control the dispensing of products according to customer credit and selection inputs. The control board will communicate with the coin mechanism and dollar bill validator (if installed); so, as credit is entered it will be shown on the digital display. If there is inadequate change available, the coin mechanism will indicate that an exact change situation exists and the control board will illuminate (continuously) the “EXACT CHANGE” L.E.D.

When a customer makes a selection on the key pad, buttons A thru D and (within 5 seconds) numbers 0 thru 9, the accumulated credit will be compared to the price set for this selection and if the credit is equal to or exceeds the set price, the corresponding motor will be energized. If the vend is successful, the price will be deducted from the credit value and the change returned.

The vend will be considered unsuccessful if the motor does not receive sufficient current or fails to reach the home position within six (6) seconds. The vend will not be attempted if the motor has already been detected as failed or if the selection made is not in the configuration of the machine. In any case, credit will not be deducted and the “MAKE ALTERNATE SELECTION” L.E.D. will flash for 3 seconds or until a new selection is made.

If there is insufficient credit for the selection made, the “CHECK PRICE” L.E.D. will flash for 3 seconds or until more money is inserted or another keypad entry is made.

If power should fail during a vend, the credit will be lost and the selected motor will not be re-energized when power returns, thus the next vend of this motor may be shorter than normal.

**SERVICE MODE**

The service mode (s1) can be entered by pressing the “MODE BUTTON” located on the control board just below the two red buttons for the changer pay out. Access is through a hole on the back of the drawer assembly (See Figure 5). By using the numbers and letters on the alphanumeric key pad, the operator can set the prices for the entire machine through the control board. To the right of the mode button (See Figure 6) are two switches; one to be used to turn the forced vend feature “on” (switch #1) and the other to turn the changer mode feature "on" (switch #2). With both option switches 1 & 2 “on”, when the service vend mode button is pressed the control board will automatically be in the service vend mode. Any other combination of these switches will enable the price setting function.

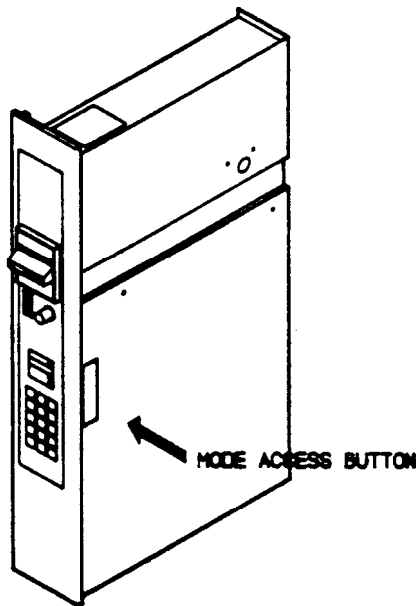

FIGURE 5

CONNECTOR	PERIPHERAL	PINS
P1	AC POWER	4
P2	BILL VALIDATOR	12
P3	CASH COUNTER	7
P4	CHANGER	11
P5	MOTORS	13
P6	KEYPAD	10

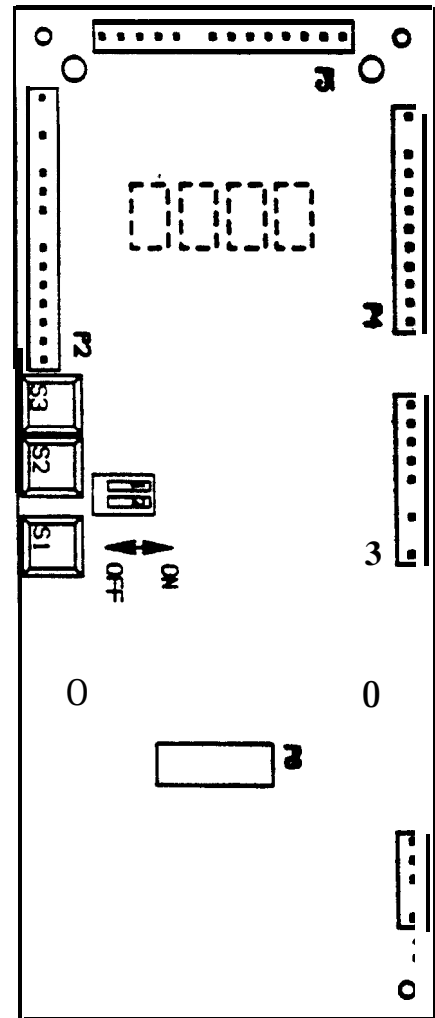

FIGURE 6





---

## DETAILED OPERATION OF CONTROL BOARD

At the time of delivery from Polyvend Inc. the control board will be set as follows:

1. All vend options will be off.
2. All of the prices will be set to \$0.50.

### -1. COIN DISPENSING

While in the service mode the control board will pay out coins out of the changer. On the control board press the second button down from the top (button S2) for the changer to pay out nickels. To pay out dimes press the top button (button S3). In order to pay out quarters press both of the pay out buttons at the same time. The changer will pay out quarters.

### 2. MOTOR/KEYPAD CONFIGURATION

This control board has two different motor configurations; one for 40 selections (normally used in Polyvend equipment) and one used for 6 selections. To determine which configuration the control board is setup for, press the mode button. Then press the letter "E" and the digital display will show "40" which means the control board is setup for the 40 selection mode or "06" will show on the digital display if the control board is setup for 6 selections. To change the configuration from "6" selections, while in the service mode, release the "E" selection button and press it again. The control board will change over to "40" selections. Exit the service mode to lock in setting.

### 3. SERVICE VEND OF MOTORS

Before going into the service mode turn both option switches to the "on" position. Press the mode button, then press the letter and number of the motor you wish to service vend (test vend). The motor should run until it returns to the home position. Upon completing the test vend of the motors reset the option switches to the desired setting and then press the mode button.

**Note:** Changing the option switches while in the service mode has no effect on the current mode until the mode button is pressed.



#### **-4. PRICE SETTING**

Before pressing the mode button one of the two options switches must be in the “off” position or both option switches turned “off”. Press the mode button, then press the letter and number of the selection for which you wish to change the price. When you press the number of that selection, release the button and press it again and the price will go up in nickel increments. If you go past the desired price, release the button and press the button in again. The price will go down in nickel increments. To change the price of the next desired selection, press the letter and number of the selection. Release the number button and press it again. The price of that selection will go up. Repeat the procedure for each selection. Upon completion, set the option switches to the desired setting and press the mode button to lock in the prices and to return to the sales mode.

#### **5. FORCE VEND MODE**

With this feature “on”, when a dollar bill is inserted the bill will be stacked and the customer will have to make a vend. If any additional bill(s) are inserted the bill will be held in escrow. When coins are inserted, a customer can make a purchase or if they press the coin return, coins will be returned. Should a vend fail on a selection after a bill(s) is inserted, the forced vend feature will be disabled and the customer can receive their money back by hitting the coin return.

To turn this feature “on”, turn the number 1 dip switch on the control board to the “on” position. Press **the mode** button one time. Press the mode button again to lock in the mode. Test the machine to ensure proper operation by inserting a one dollar bill and then pressing the coin return. Then bill should not be returned.

#### **6. CHANGER MODE**

With this feature turned “on” regardless of accumulated credit or maximum price, the dollar bill(s) will automatically be sent to the stacker. Any additional bill(s) inserted will be stacked. If you press the coin return you will receive the dollar(s) in the highest denomination the changer can pay out. If this feature is turned “off” (with escrowing validator installed), the last dollar inserted will be held in escrow. When you hit the coin return you will receive the last dollar bill inserted and any additional bill(s) inserted will be in the form of change paid out by the changer.

Note: If both options are “on”, the forced vend option will be the functioning feature. If both options are “off”, and the coin return is pushed, the money will be returned.

## POLYVEND SHIPPING POLICY

The following information is to assist you in assuring safe delivery of your merchandise and in expediting of freight damage claims.

**Our** terms of sale are F.O.B. our factory. The responsibility for damage in transit is the carrier's whether it be visible or concealed damage. We have taken every precaution to ensure safe arrival of this equipment, but our responsibility ceases the moment the shipment is turned over to the carrier.

**Acceptance** of this shipment by the carrier is an acknowledgment that the equipment was delivered to them in good condition and properly packed. The carrier who delivers this merchandise to your door is responsible for its safe delivery.

### **PROCEDURE FOR VISIBLE DAMAGE**

1. IT IS VERY IMPORTANT TO INSPECT ALL FREIGHT DELIVERIES, WHETHER MACHINE OR PARTS, IMMEDIATELY. If there is any visible damage you have the right to either refuse the merchandise or accept the damaged shipment. If you accept it, make certain that you have the delivery personnel note the nature and extent of damage on the freight bill.
2. After you determine the extent and cost of the damage, notify the delivering carrier's office by phone and confirm with a written notice within 15 days requesting an inspection of the damaged merchandise. Keep a copy of the inspection request for claim purposes. Do not destroy the packing material until shipment is inspected and claim is settled.
3. When the inspector arrives, ask for a claim form. In filing a claim, you may make a cash settlement with the carrier for the full invoice price of the merchandise or contact Polyvend Inc., and make arrangements to have merchandise returned for repair and file a claim for repair charges. Do not return "DEADHEAD". Do not claim more than the cash price of the machine, plus freight.

## **SHOCK WATCH PROCEDURES**

On each machine shipped out of Polyvend Inc. there is an indicator called a Shock Watch, which will turn from white to red if the machine has received a severe impact. The shock watch is a red hexagon shaped label mounted on the front glass of the machine. Just above the shock watch will be a label on the outside of the machine with instructions on what to do when the machine is received and what to do if the shock watch has changed color from white to red. Inspect the shock watch “IMMEDIATELY” upon receipt of the machine. **DO NOT SIGN THE BILL OF LADING** until you have inspected the shock watch to see if it has turned from white to red. If the shock watch has turned red note this on the bill of lading. Inspect the machine “IMMEDIATELY” for damage both on the exterior and interior of the machine. If damage is found follow the procedures for concealed damage.

### **PROCEDURE FOR CONCEALED DAMAGE**

1. If there is no visible damage, **YOU MUST OPEN THE SHIPMENT WITHIN 15 DAYS AND INSPECT FOR CONCEALED DAMAGE.** If there is concealed damage, notify the delivering carrier by phone immediately asking for an inspection. Confirm the request in writing and keep a copy for claim purposes. If you fail to notify the carrier within 15 days of delivery by telephone and in writing, the freight company is no longer liable for damage and will probably refuse your claim. Do not destroy packing material until shipment is inspected and claim is settled.
2. After inspection by the carrier, file a claim for damages at once. On concealed damage, unless it can be proven that the carrier is responsible for the damage, they will probably want to settle on a compromise basis. Therefore, the faster you inspect your delivery and notify the carrier, the better the chances for full settlement. If the claim is disallowed, check on the possibility of a compromise.

### **PROCEDURES FOR SHORTAGES**

1. If the shipment delivered to you is not in accordance with the quantity of cartons shown on your receipt, do not accept it until shortages are noted on the Freight Bill or Bill of Lading and signed by the truck driver. Failure to do this releases the carrier from any responsibility.
2. If the shorted item(s) are not delivered within a reasonable time, file a claim with the delivering carrier for the invoice or cash price of the item(s).

**NOTE:** Claims for loss or damage will **NOT BE DEDUCTED FROM YOUR INVOICE** while you wait adjustment of such claims.



**DRAWINGS AND PARTS LISTS**

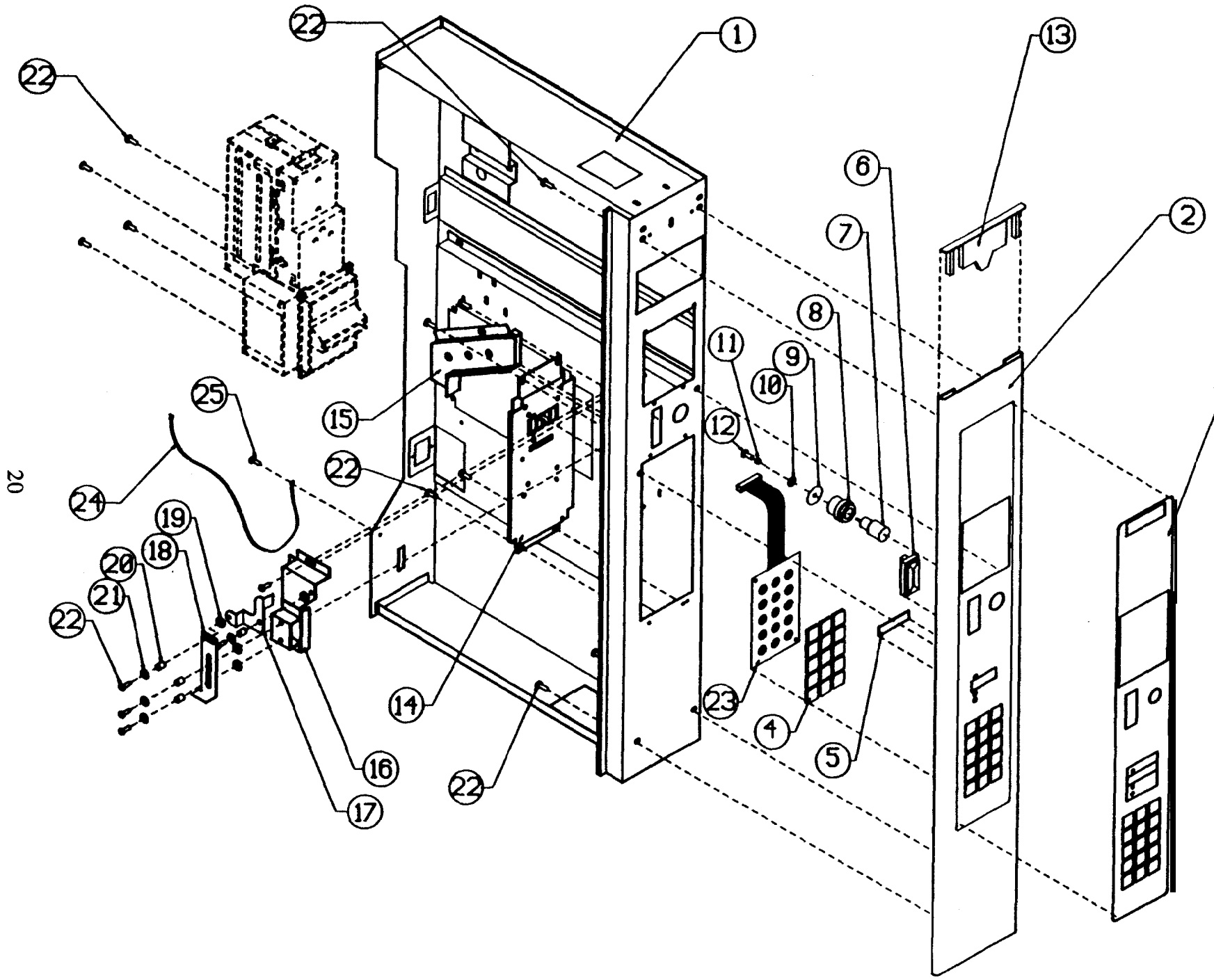

20

**SLIDING DRAWER ASSEMBLY  
PARTS LIST**

ITEM	DESCRIPTION	PART NO	QTY
1	DRAWER W/A	21522BLK	1
2	ESCUTCHEON	2144203	
3	ESCUTCHEON DECAL	21403	
4	SELECTION BUTTONS SET	21567SET	1
5	CLEAR LENS	21550	
6	COIN INLET	17948	
7	COIN REJECTION BUTTON	21125	
8	COIN REJECTION BUSHING	21126	
9	FLAT WASHER	16154	1
10	WASHER	13419	1
11	SLEEVE SPACER	2220 1	1
12	SCREW #8 18 X 1/2	24167	1
13	ESCUTCHEON CAP	17916BLK	
14	CONTROLLER BRACKET	21447	1
15	COIN CHUTE ASSEMBLY	23000	1
16	COIN REJECT BASE W/A	21474	1
17	COIN REJECT CAM	21475	
18	COIN REJECT PLUNGER	21476	1
19	FLAT WASHER	04280	7
20	STEEL SPACER	00827	4
21	FLAT WASHER	03276	4
22	SCREW	01298BLK	20
23	KEYPAD 3 X 5	21517	
24	DRAWER GROUND WIRE	20797	1
25	S C R E W #8	01715	3



26

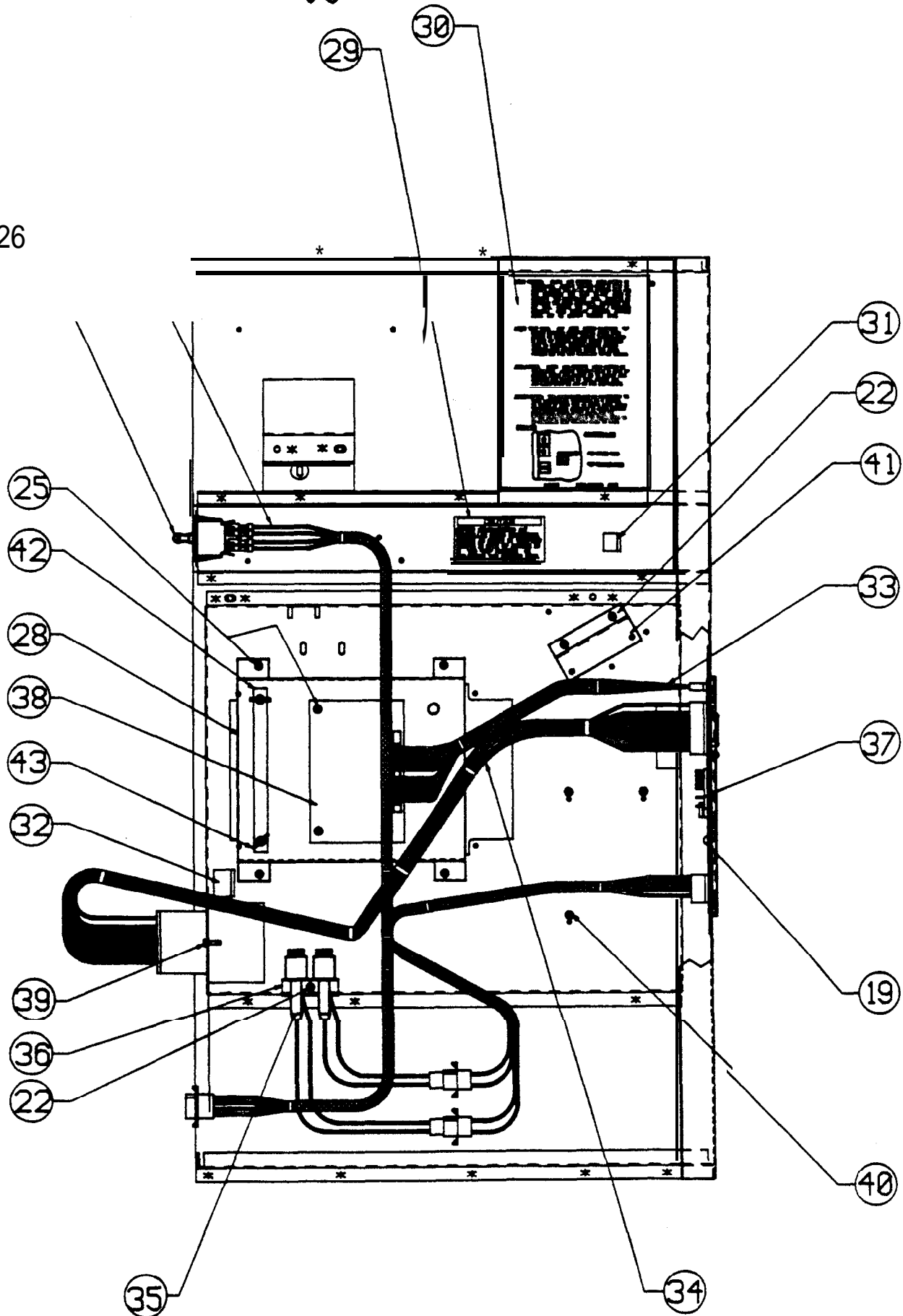

**SLIDING DRAWER ELECTRICAL WIRING  
PARTS LIST**

ITEM	DESCRIPTION	PART NO.	QTY.
26	INTERLOCK SWITCH	19746	1
27	POWER HARNESS	21532P	
28	CONTROLLER COVER	2330901	1
29	DECAL "CAUTION"	19819	1
30	DECAL SERVICE PROGRAM	21509	
31	CLAMP 3/8	0853801	1
32	CLAMP 5/8	0853802	
33	INNERCONNECT HARNESS	21538	
34	HARNESS COIN MECHANISM	2155101	
35	FUSE ASSEMBLY	17920	2
36	FUSE MOUNTING BRACKET	18060BLK	
37	CONTROLLER	21513	
38	HARNESS CONTROL BOARD	21528	
39	SCREW #6-20 X 3/16	18370BLK	4
40	SCREW #8-32 X 3/8	11894	3
41	COIN CHUTE MOUNTING BRACKET	21523BLK	
42	HARNESS CLAMP	0433201	1
43	WING NUT	19170	2

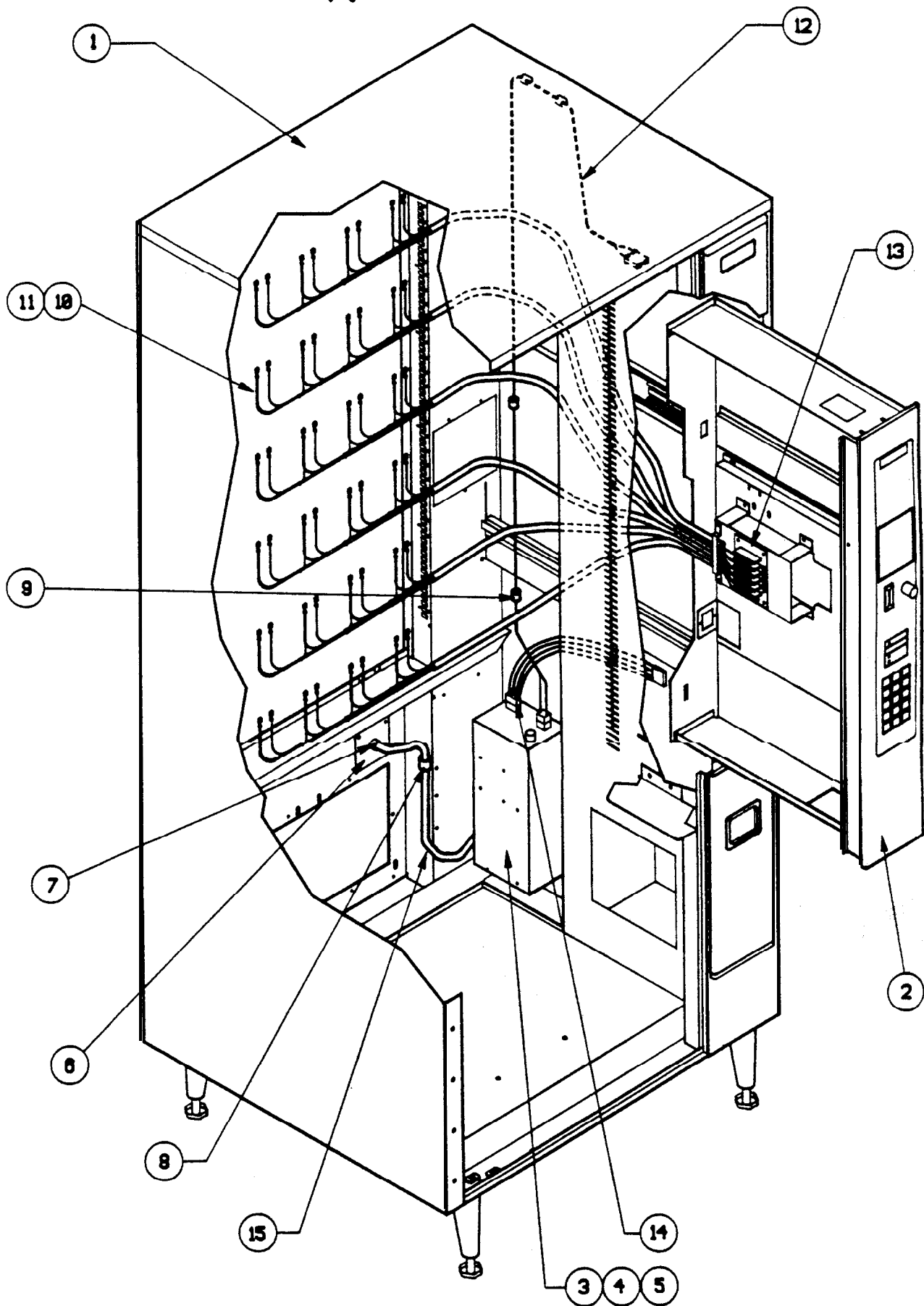



MAIN CABINET ELECTRICAL WIRING  
PARTS LIST

ITEM	DESCRIPTION	PART NO.	QTY
	CABINET W/A	21428TDG	1
2	SLIDING DRAWER ASSEMBLY	21507	1
3	POWER BOX ASSEMBLY	21508	1
4	POWER BOX MOUNT	21478	1
5	SCREW #8-18 X 3/8	01298BLK	4
6	POWER CORD IENTRANCE	23587	1
7	STRAIN RELIEF BUSHING	02438	1
8	HARNESS CLAMP	0853802	1
9	HARNESS CLAMP	0853801	4
10	TRAY MOTOR HARNESS 8 SEL.	2146501	4
11	TRAY MOTOR HARNESS 8 SEL.	2146501	2
12	LAMP ASSEMBLY HARNESS	21498	1
13	PC BOARD TRAY HARNESS CONNECTOR	21528	
14	DRAWER ASSEMBLY POWER HARNESS	21531	

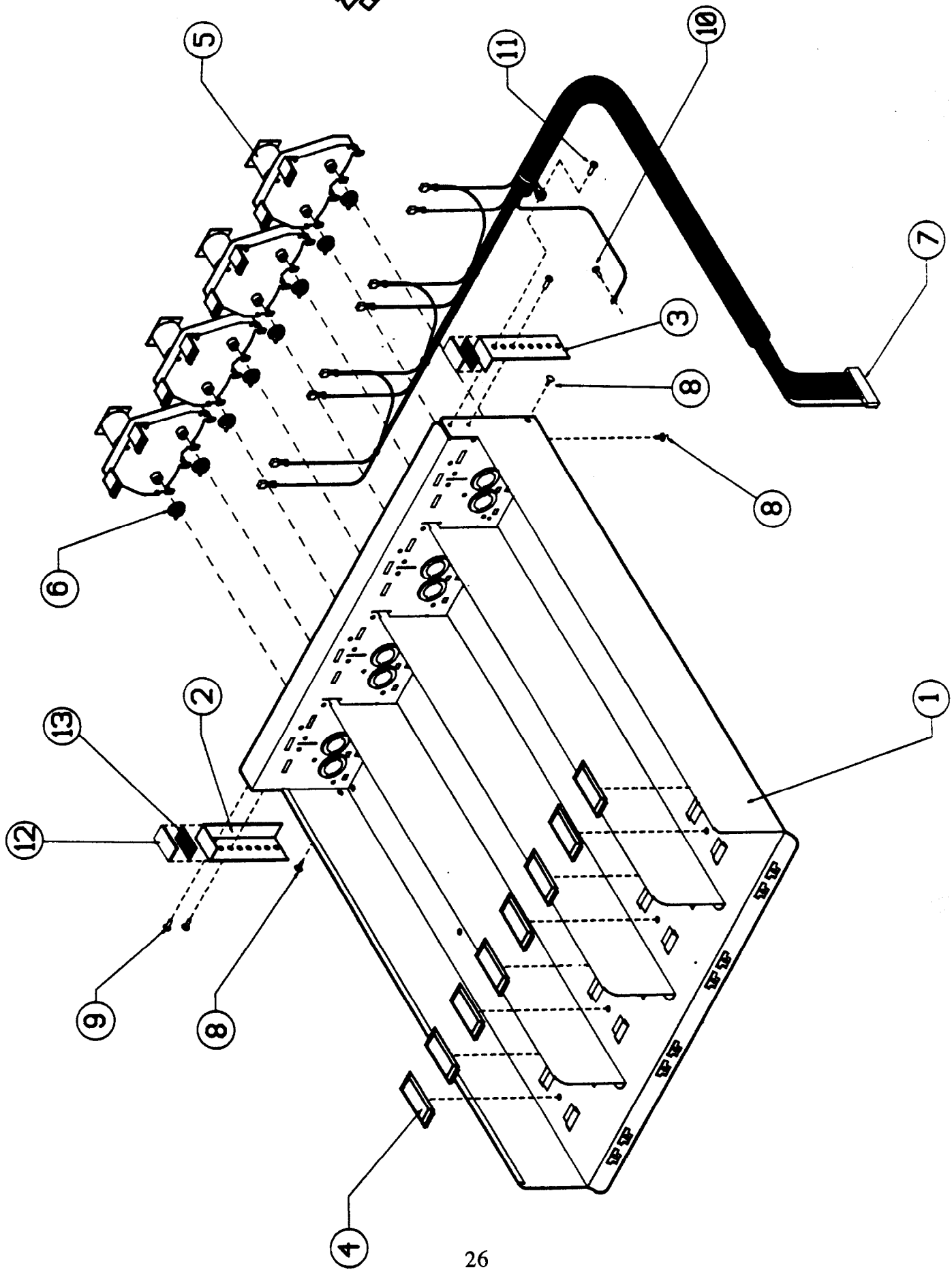

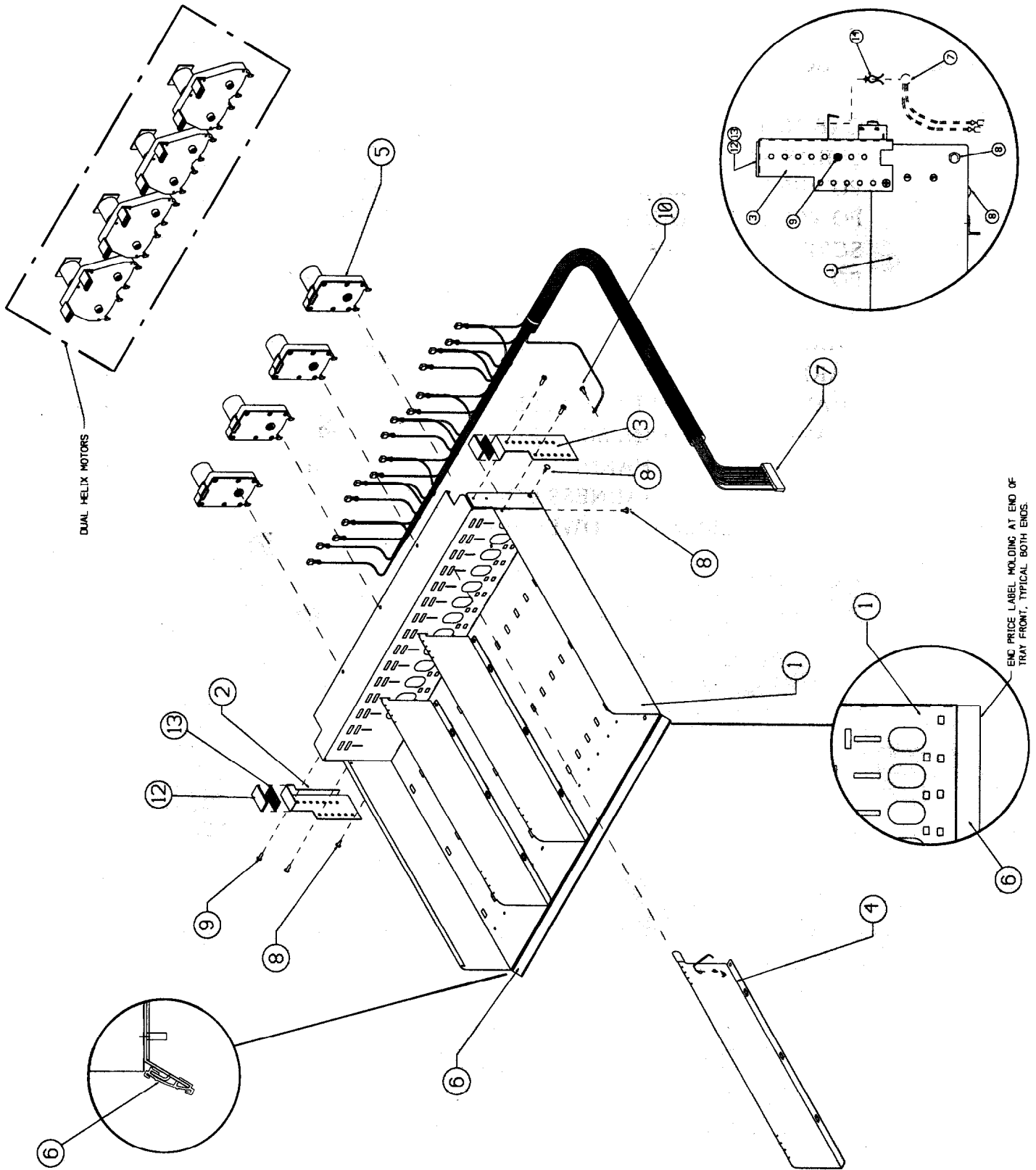

**SNACK TRAY ASSEMBLY  
FIXED DIVIDERS  
4-SELECTION  
PARTS LIST**

ITEM	DESCRIPTION	PART NO.	QTY
	COMPLETE TRAY ASSEMBLY (DUAL HELIX)	21420	
1	TRAY W/A	2141801	1
2	TILT BRACKET L.H.	2145302	1
3	TILT BRACKET R.H.	2145303	1
4	WEAR PLATE	210-3010B	8
5	MOTOR	21365	4
6	HUB COUPLING	17537	8
7	TRAY HARNESS 4-SEL.	2146301	1
8	CANOE CLIP	210-8021	4
9	SCREW #8-18 X 3/8	01298BLK	3
10	SCREW #8-32 X 3/8	01715	1
11	SCREW #8-18 X 1/2	026 14BLK	1
12	TILT OUT BRACKET PAD	21438	2
13	ADHESIVE PAD	18880	1.312"

**SNACK TRAY ASSEMBLY  
REMOVABLE DIVIDERS  
4-SELECTION  
PARTS LIST**

**NOTE: NEW STYLE TRAYS INSTALLED IN ALL MACHINES  
STARTING WITH SERIAL #1811 & HIGHER.**

ITEM	DESCRIPTION	PART NO.	QTY
	COMPLETE TRAY ASSEMBLY (DUAL HELIX)	2415516	
1	TRAY W/A	23995	1
2	TILT BRACKET L.H.	24128LH	1
3	TILT BRACKET R.H.	24128RH	1
4	DIVIDER ASSEMBLY	24000	3
5	*MOTOR (DUAL HELIX)	23216	4
6	MOLDING, PRICE LABEL	240420 1	1
7	TRAY HARNESS 4-SEL.	2146301	1
8	CANOE CLIP	210-8021	4
9	SCREW #8-18 X 3/8	01298BLK	4
10	SCREW #8-32 X 3/8	01715	1
12	TILT OUT BRACKET PAD	21438	2
13	ADHESIVE PAD	18880	1.312"
14	STANDOFF-PURSE LOCK	24002	3

\* FOR LARGE SINGLE HELIX, USE MOTOR PART NO. 23894



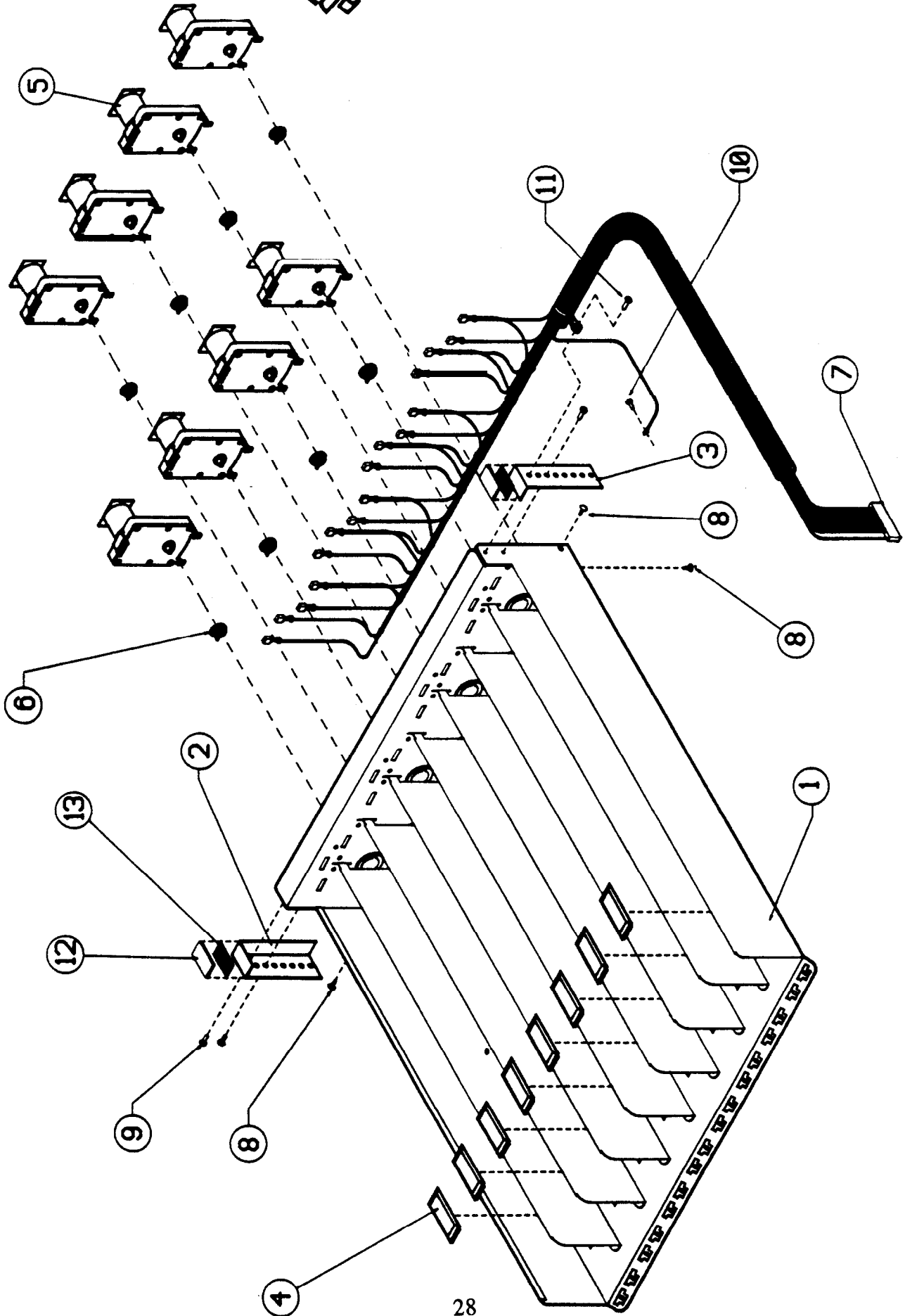

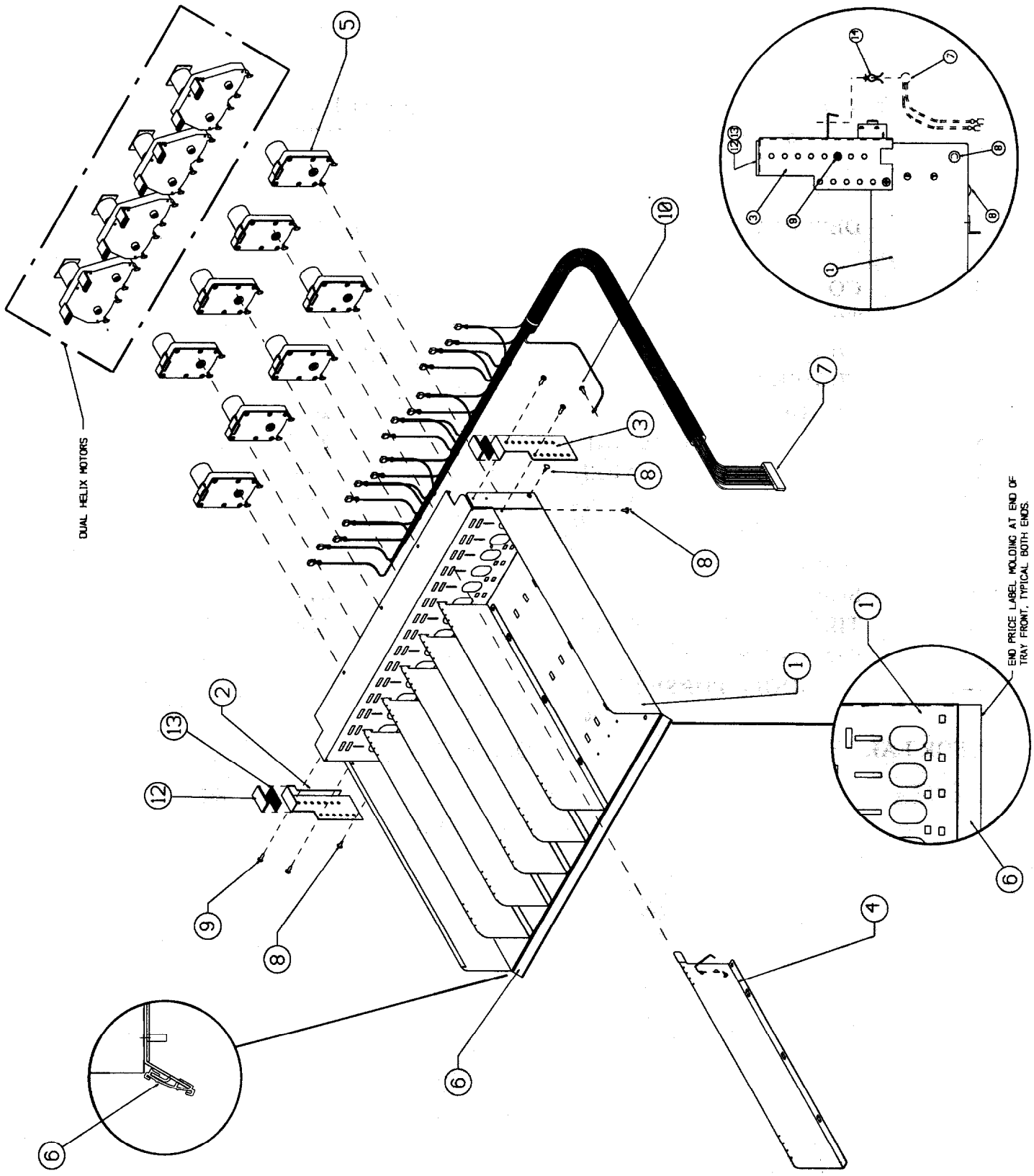



**CANDY TRAY ASSEMBLY  
FIXED DIVIDERS  
S-SELECTION  
PARTS LIST**

ITEM	DESCRIPTION	PART NO.	QTY
	COMPLETE TRAY ASSEMBLY	2142006	
1	TRAY W/A	2141805	1
2	TILT OUT BRACKET L.H.	2145302	1
3	TILT OUT BRACKET R.H.	2145303	1
4	WEAR PLATE	210-30108	8
5	MOTOR	18365-3CC	8
6	HUB COUPLING	17537	8
7	TRAY HARNESS 8 SEL.	21527P	1
8	CANOE CLIP	210-8021	4
9	SCREW #8-18 X 3/8	01298BLK	3
10	SCREW #8-32 X 3/8 PH	01715	
11	SCREW #8-18 X 1/2	02614BLK	1
12	TILT OUT BRACKET PAD	21438	2
13	ADHESIVE PAD	18880	1.312"



**CANDY TRAY ASSEMBLY  
REMOVABLE DIVIDERS  
S-SELECTION  
PARTS LIST**

**NOTE: NEW STYLE TRAYS INSTALLED IN ALL MACHINES  
STARTING WITH SERIAL #1811 & HIGHER.**

ITEM	DESCRIPTION	PART NO.	QTY
	COMPLETE TRAY ASSEMBLY	2415517	
1	TRAY W/A	23995	1
2	TILT OUT BRACKET L.H.	24128LH	
3	TILT OUT BRACKET R.H.	24128RH	1
4	DIVIDER ASSY.	24000	7
5	MOTOR (SINGLE HELIX)	23894	8
6	MOLDING, PRICE LABEL	240420 1	
7	TRAY HARNESS 8-SEL.	21527P	1
8	CANOE CLIP	210-8021	4
9	SCREW #8-18 X 3/8	01298BLK	4
10	SCREW #8-32 X 3/8 PH	01715	1
12	TILT OUT BRACKET PAD	21438	2
13	ADHESIVE PAD	18880	312"
14	STANDOFF-PURSE LOCK	24002	3

**MAIN CABINET ASSEMBLY  
PARTS LIST**

TO BE USED IN CONJUNCTION WITH PAGES 31 AND 32

<b>ITEM</b>	<b>DESCRIPTION</b>	<b>PART NO.</b>	<b>QTY</b>
1	CABINET W/A	21408TOM	1
2	DRAWER ASSEMBLY TOM'S SLIDING	21507	1
3	UPPER ESCUTCHEON PLATE TOM'S	21515	1
4	LOWER ESCUTCHEON PLATE TOM'S	2315103	1
5	END CAP ESCUTCHEON	17917BLK	2
6	MID ESCUTCHEON CAP	17916	1
7	TOM'S DECAL	21518	1
8	COIN RETURN TRIM	17868BLK	1
9	COIN RETURN CUP BLACK	17866BLK	1
10	COIN CUP DOOR	17865BLK	1
11	COIN HOPPER	17823	1
11A	COIN HOPPER LOCKING PLATE	20132	1
11B	COIN HOPPER SHUTE (NOT SHOWN)	20656	1
12	COIN BANK	2307101	1
13	RIGHT HAND RAIL BLACK	234680 1	6
14	R.H. TRAY SUPPORT STIFFENER	2337102	6
15	REAR DOOR COVER PLATE	21512	1
16	R.H. PRODUCT DEFLECTOR	23867BLK	1
17	DRAWER SLIDE	17964	1
18	SCREW #8-8 X 3/8	01298BLK	16
19	L.H. RAIL BLACK	2158401	6
20	TRAY FRONT SUPPORT	2142101	6
21	CANOE CLIP	210-8012	12
22	L.H. PRODUCT DEFLECTOR	23868BLK	1
23	L.H. TRAY SUPPORT STIFFENER	2337 103	6
24	TAPERED LEGS, W/A	230770 1	4
25	LEG LEVELER	19765	4
26	BOLT 5/16-18 X 5/8	19302	16
27	COIN BOX HANDLE	21470	1
28	POP RIVET	00729	2
29	COVER PLATE	225 12DG	1
30	INSULATION REAR	233002	1
31	SERVICE DOOR LOCK PLATE (NOT SHOWN)	17996BLK	3

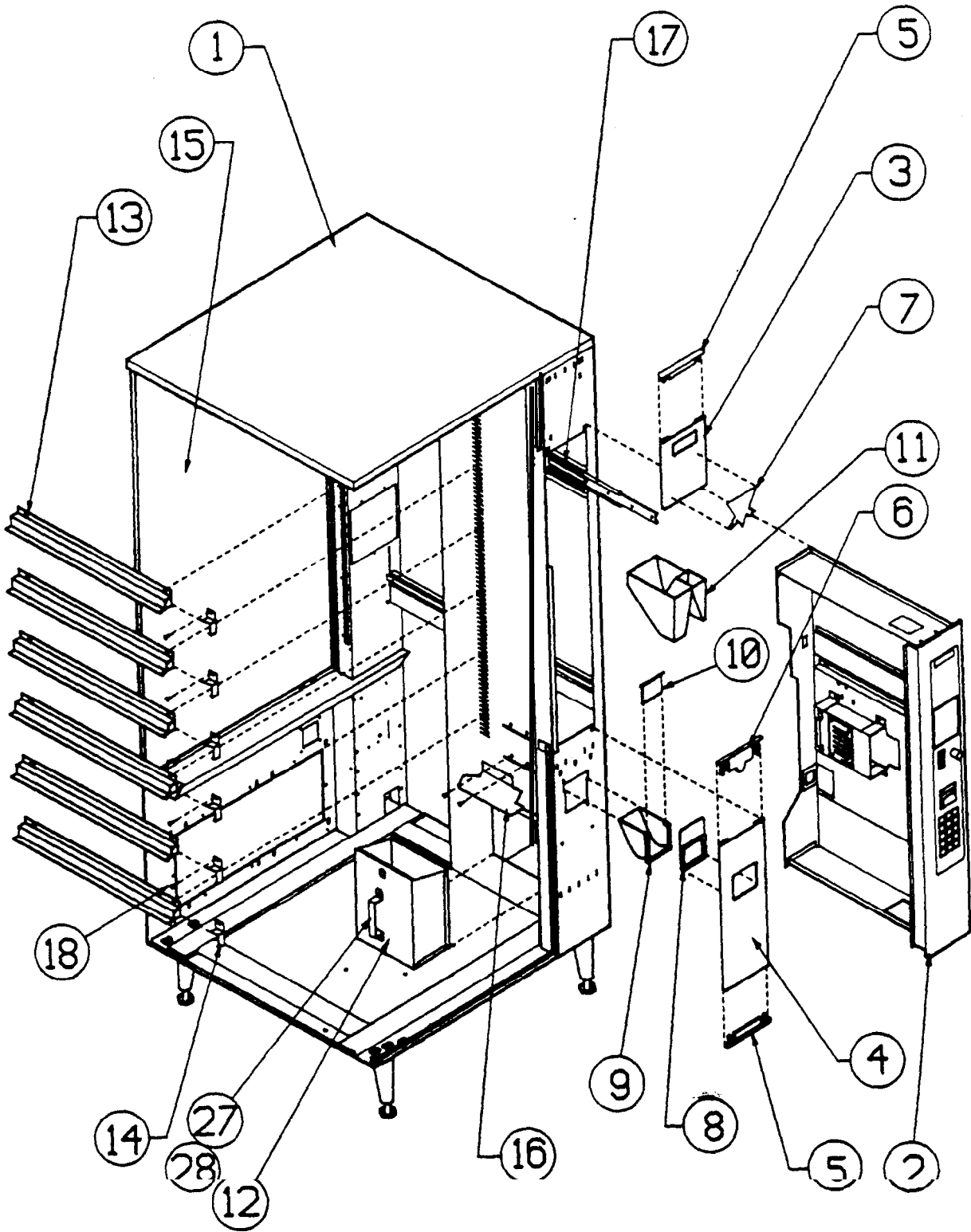

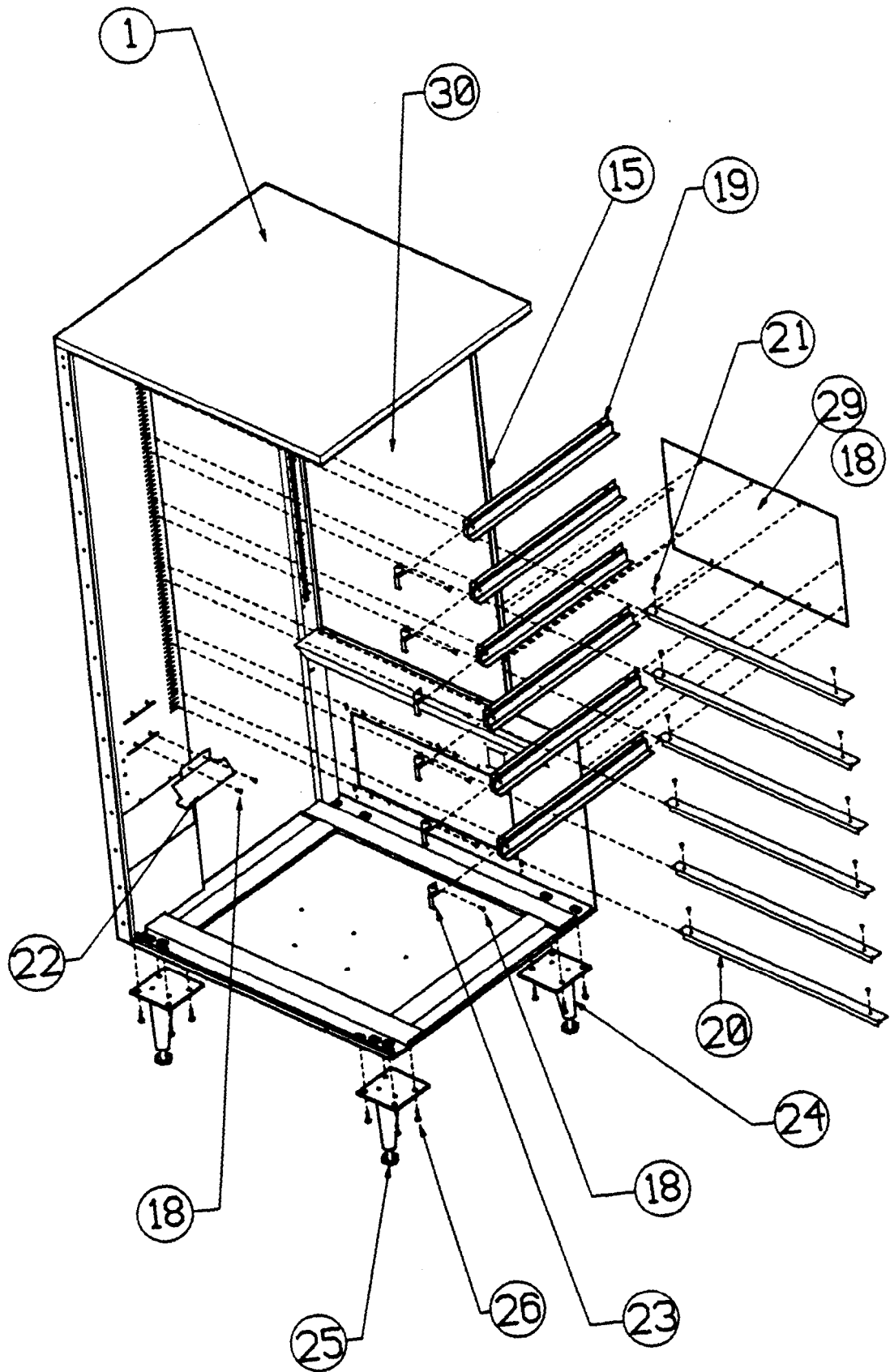

**HELIX ASSEMBLY**  
**“USED WITH FIXED DIVIDER TRAY ASSEMBLIES”**

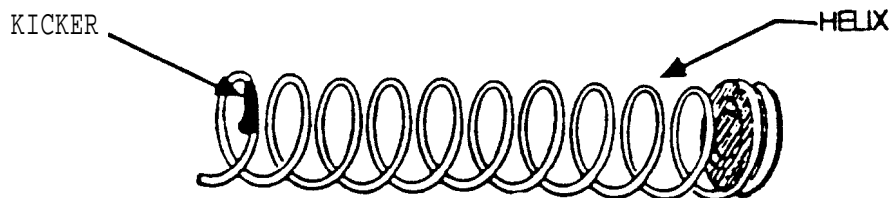

SNACK			CANDY		
Helix	Part No.	Product Thickness	Helix	Part No.	Product Thickness
10 ct	2208 104	1 1/2"	14 ct	220800 1	1"
8 ct	2208	1 7/8"	12 ct	2208003	1 1/4"
6 ct	1837406	2 1/2" (optional)	10 ct	2208002	1 1/2"
SEPARATE KICKER - 18303			SEPARATE KICKER - 18302		

**HELIX ASSEMBLY**  
**“USED WITH REMOVABLE TRAY ASSEMBLIES”**

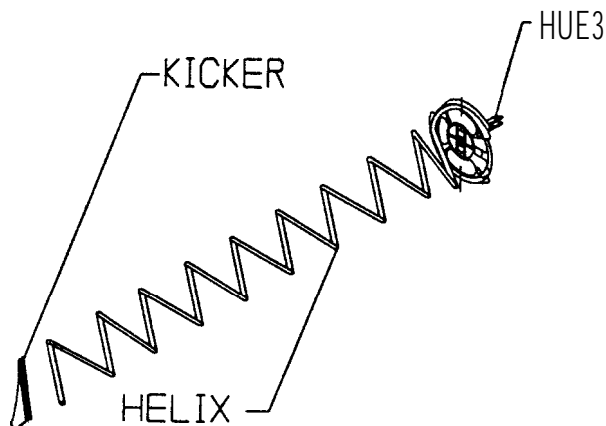

PASTRY			CANDY		
Helix	Part No.	Product Thickness	Helix	Part No.	Product Thickness
14 ct	23978L3	1"	22 ct	23977L6	5/8"
10 ct	23978L2	1 1/2"	14 ct	23977L4	1"
8 ct	23978L1	1 7/8"	12 ct	23977L3	1 1/4"
6 ct	23978L4	2 1/2"	10 ct	23977L2	1 1/2"
SEPARATE KICKER - 18303		HUB ASSEMBLY 23886	SEPARATE KICKER - 210-3020B		HUB ASSEMBLY 23886

**DUAL HELIX**

Helix	Part No. Left	Part No. Right	Product Thickness
18 ct	23977R5	23977L5	1/2"
14 ct	23977R4	23977L4	7/8"
<b>12 ct</b>	23977R3	23977L3	1"
10 ct	23977R2	23977L2	1 1/4"
8 ct	23977R1	23977L1	1 1/2"

SEPARATE KICKER - 210-3020B HUB ASSEMBLY 23886



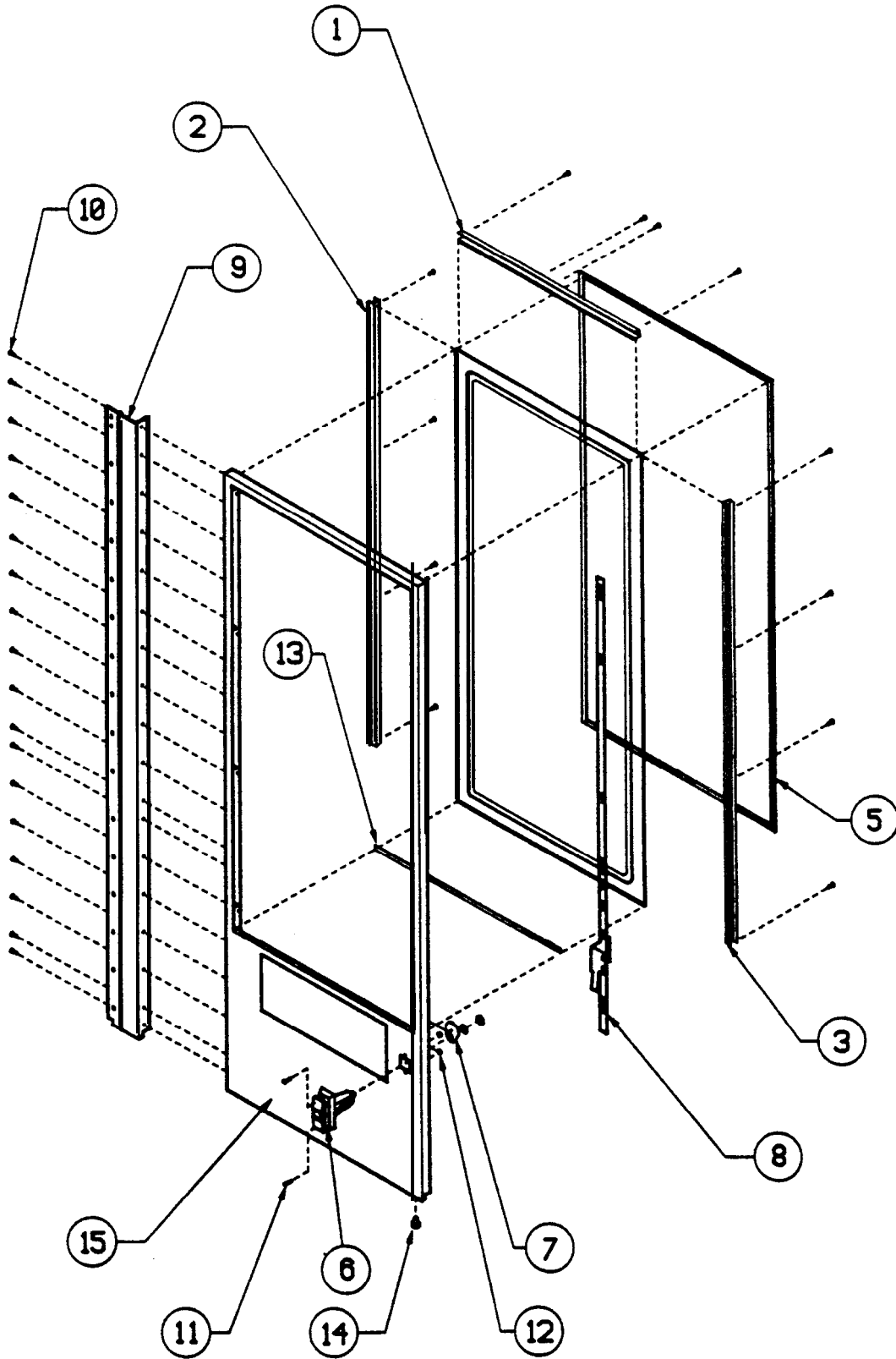

**SERVICE DOOR ASSEMBLY  
PARTS LIST**

ITEM	DESCRIPTION	PART NO.	QTY
	DOOR ASSEMBLY COMPLETE	2 1405DG	1
1	TOP GLASS HOLDER	18499BLK	1
2	LEFT SIDE GLASS HOLDER	<b>17954BLK</b>	1
3	RIGHT SIDE GLASS HOLDER	<b>17954BLK</b>	1
4	SERVICE DOOR GLASS (TEMPERED)	18761	1
5	SERVICE DOOR GASKET	17970	<b>12.6'</b>
6	LARGE HANDLE DOOR LOCK	19379BLK	1
7	CAM-LOCK	<b>17457BLK</b>	1
8	LOCKING BAR	<b>18001BLK</b>	1
9	SERVICE DOOR HINGE	22030DG	1
10	SCREW #8-8 X 3/8	01298BLK	<b>35</b>
<b>11</b>	CARRIAGE BOLT #10-24 X 3/4	15249	<b>2</b>
<b>12</b>	STAR LOCKNUT #10-24	19566	<b>2</b>
<b>13</b>	NEOPRENE STRIPPING	18244500	<b>2.33'</b>
<b>14</b>	RETAINING PLUG	18442	1
<b>15</b>	SERVICE DOOR W/A	21406DG	
<b>16</b>	ROLL PIN T-HANDLE (NOT SHOWN)	19171	1
<b>17</b>	DOOR STOP WIRE TYPE (NOT SHOWN)	18907	

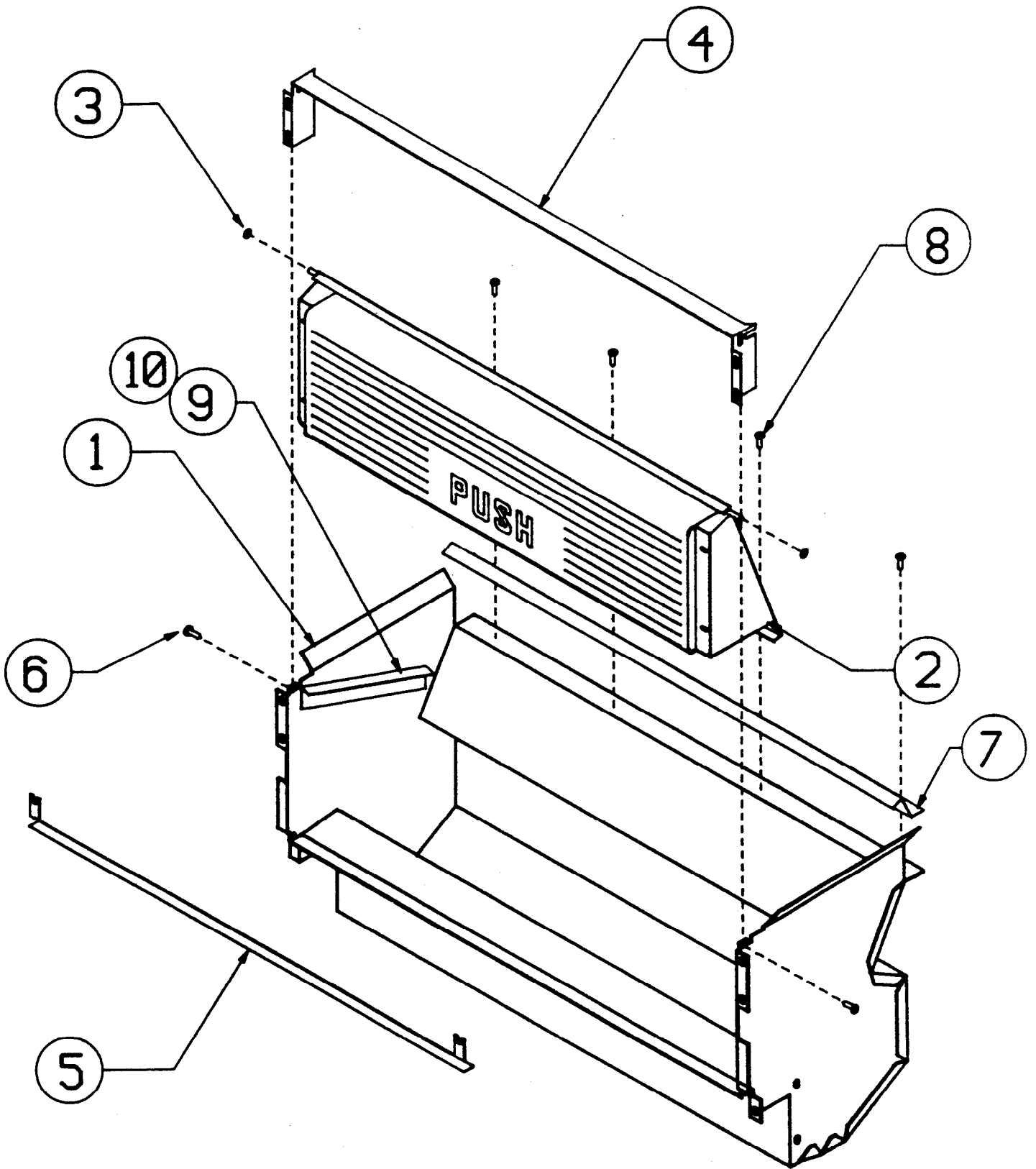



**PRODUCT DELIVERY COMPARTMENT  
PARTS LIST**

<b>ITEM</b>	<b>DESCRIPTION</b>	<b>PART NO.</b>	<b>QTY</b>
1	DELIVERY COMPARTMENT ASSEMBLY	18492	1
2	DOOR ASSEMBLY DELIVERY COMPARTMENT	19987E	1
3	WASHER 1/4" NYLON	18684	2
4	DELIVERY DOOR RETAINER	<b>18672BLK</b>	1
5	PRODUCT DEFLECTOR	20126MBK	1
6	SCREW #8- 18 X 3/8	01298BLK	2
7	BRACKET ANTI-THEFT	232290 1	1
8	SCREW PANHEAD	13140	4
9	BRACKET ANTI-THEFT LEFT SIDE	23838LHB	1
	BRACKET ANTI-THEFT RIGHT SIDE	23838RHB	
10	POP RIVET	00729	<b>6</b>
11	ANTI-VANDAL KIT	23245	

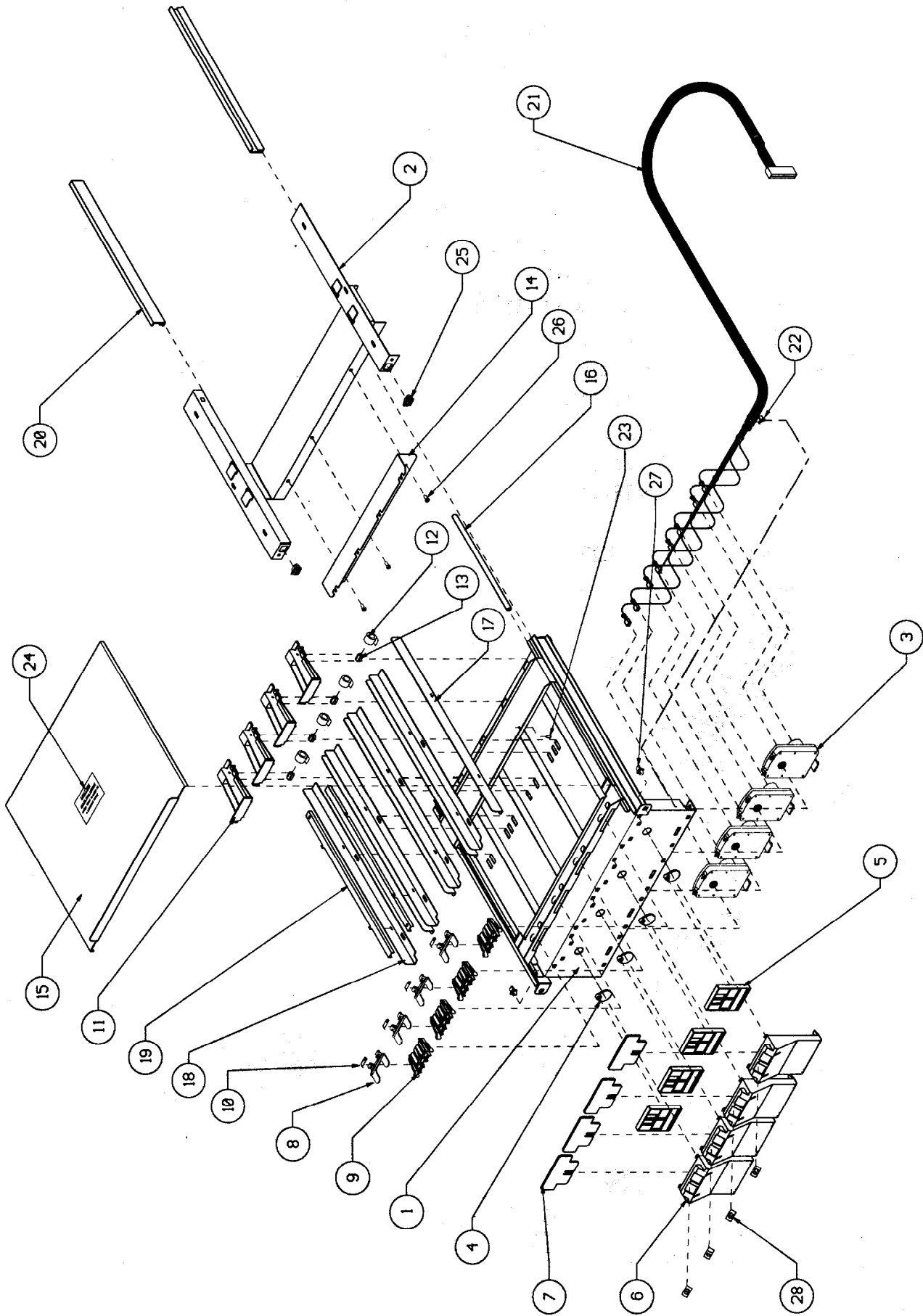



**NEW STYLE GUM AND MINT ASSEMBLY  
R-32/ULTRA VENDOR-32  
PARTS LIST**

**NOTE:** New style gum and mint assembly installed in machines with serial number 18 1 1 and higher.

ITEM	DESCRIPTION	PART NO.	QTY
-	GUM AND MINT ASSEMBLY COMPLETE	2395004	1
1	T R A Y W/A	239260 1	1
2	SLIDE SUPPORT W/A	2398101	1
3	MOTOR	23894	4
4	CAM	23888	4
5	ACTUATOR	23889	4
6	GUIDE BLOCK	23890	4
7	WINDOW	23891	4
8	GATE	23892	4
9	PIVOT	23893	4
10	SPRING	23908	4
11	PRODUCT PUSHER	19075	4
12	SPRING CONSTANT FORCE	19165	4
13	ROLLER	23953	4
14	BRACKET - SPRING RETURN	23927	1
15	COVER - MID SIZE	239820 1	1
16	EDGE TRIM	23911	2
17	PRODUCT GUIDE R.H.	2391202	4
18	PRODUCT GUIDE L.H.	2391203	4
19	HEIGHT ADJUSTER BRACKET (OPTIONAL)	19166	2
20	SLIDE-UHMW EXTRUSION	23914	2
21	HARNESS	21574	1
22	STRAIN RELIEF	23945	1
23	CANOE CLIP	19176	2
24	DECAL "CAUTION"	19174	1
25	LATCH	24123	2
26	SCREW #8 - 18 X 3/8	01298BLK	2
27	STRIKE	24124	2
28	SELECTION NUMBER LABEL.	24134	A.R

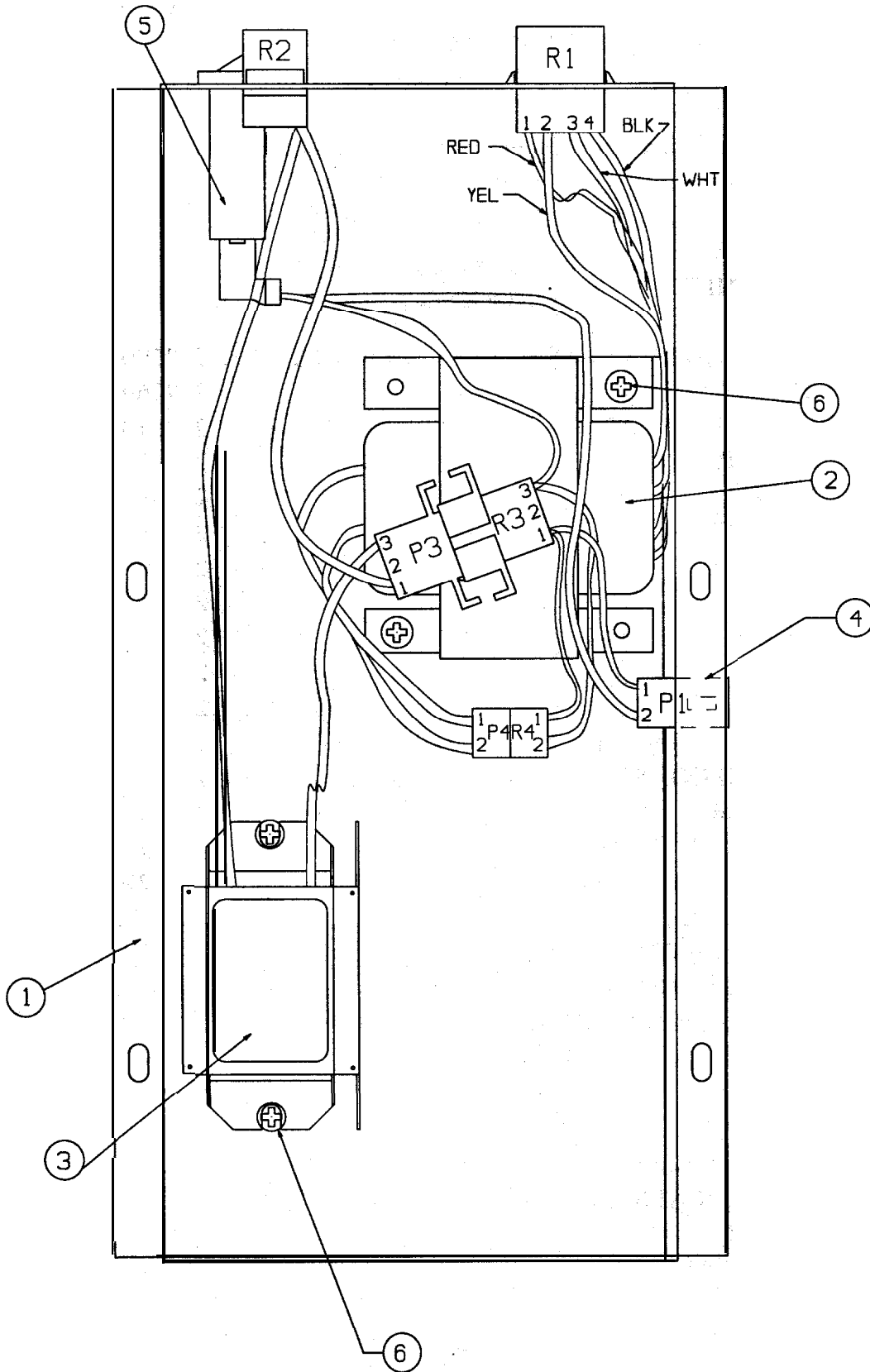

### POWER BOX ASSEMBLY



POWER BOX ASSEMBLY  
PARTS LIST

ITEM	DESCRIPTION	PART NO.	QTY
	POWER BOX ASSEMBLY	24344	1
1	BOX, COMPONENTS COVER	21534	1
2	TRANS. ASSY., MINI VENDOR	18283	1
3	BALLAST ASSY. 15W 120V	24343	1
4	HRNS., CKT. BRKR, TOM'S	21533	1
5	CIRCUIT BREAKER 2.0A	2233001	1
6	SCREW, SEMS	01715	4

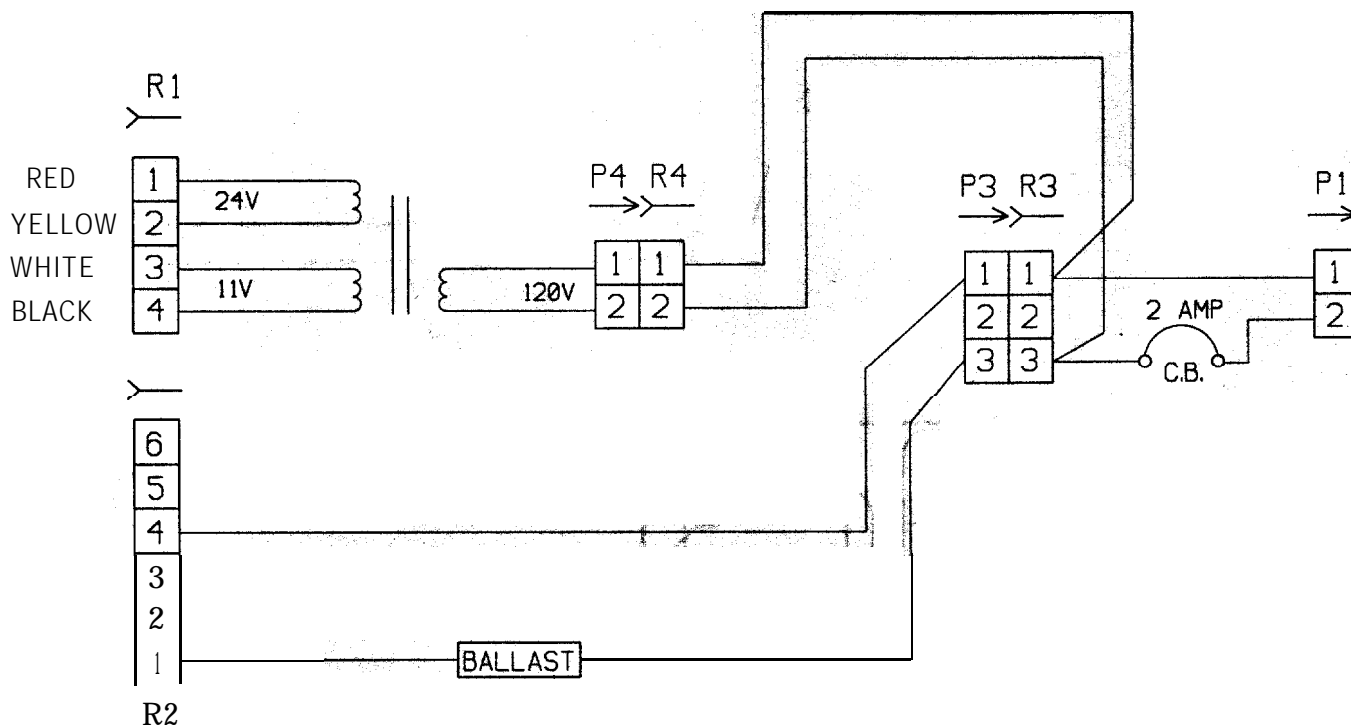

**SCHEMATIC DIAGRAM**



LAMP ASSEMBLY  
PARTS LIST

ITEM	DESCRIPTION	PART NO.	QTY
	LAMP ASSEMBLY	24353	1
1	LAMP BULB - 15 WATT	00101	1
2	TUBE POLYCARBONATE	21562	1
3	END CAP	19708	2
4	SCREW	13261	2
5	LAMP BRACKET	24402	2
6	HARNESS STD. LAMP ASSY.	24352	1
	STARTER FS-2	24398	1

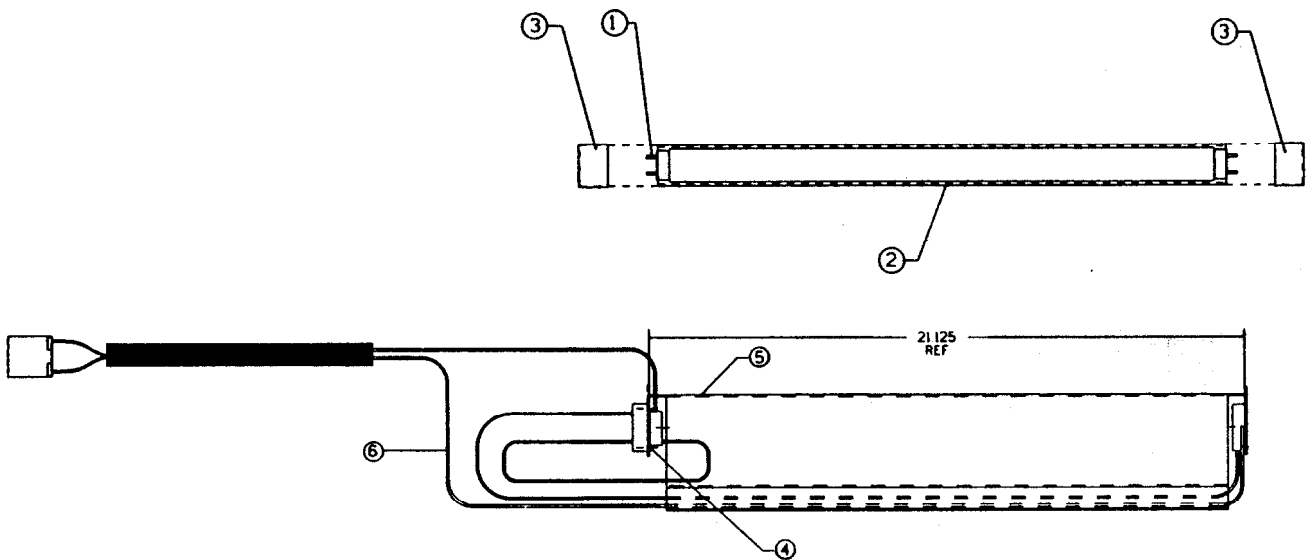





POWER BOX SCHEMATIC

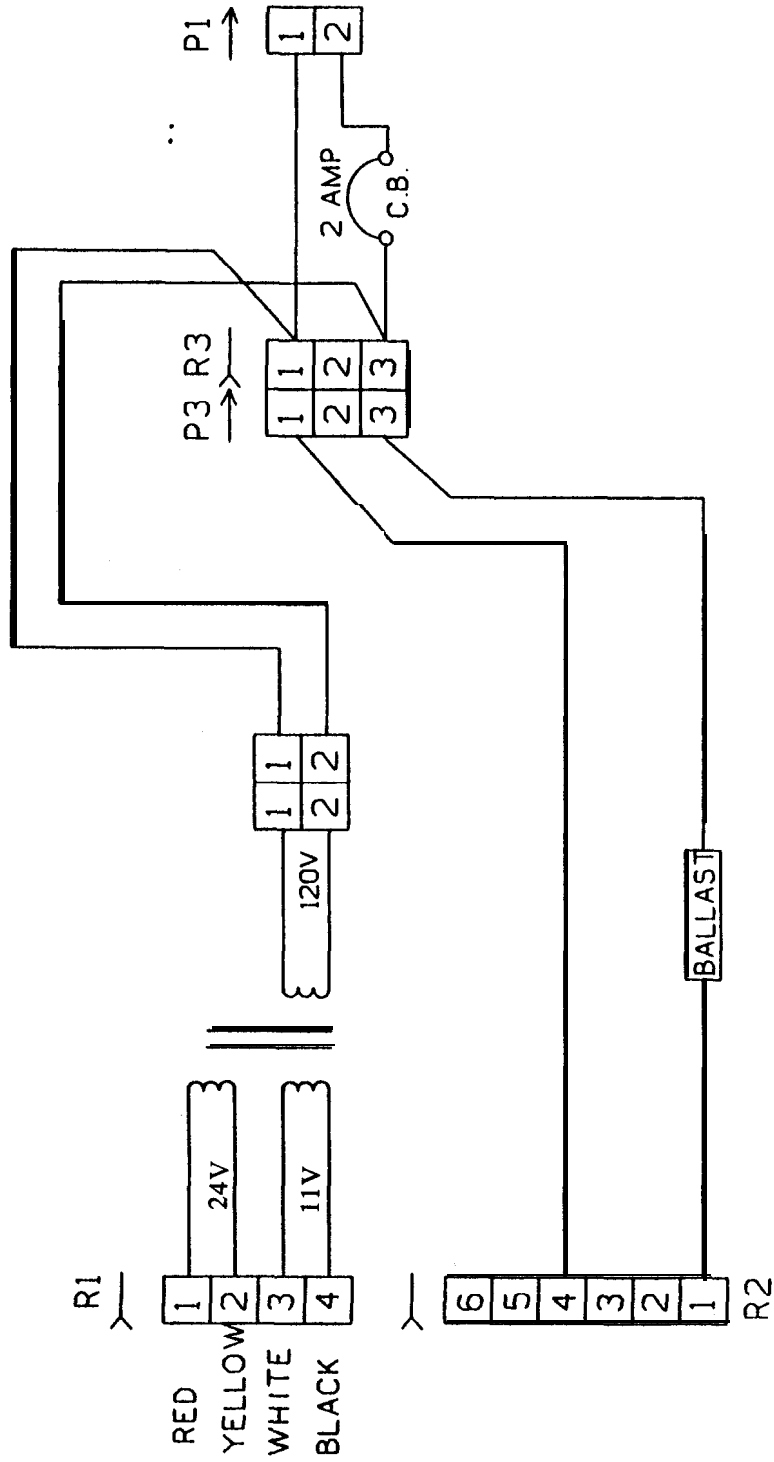



COMPLETE ELECTRICAL MACHINE SCHEMATIC

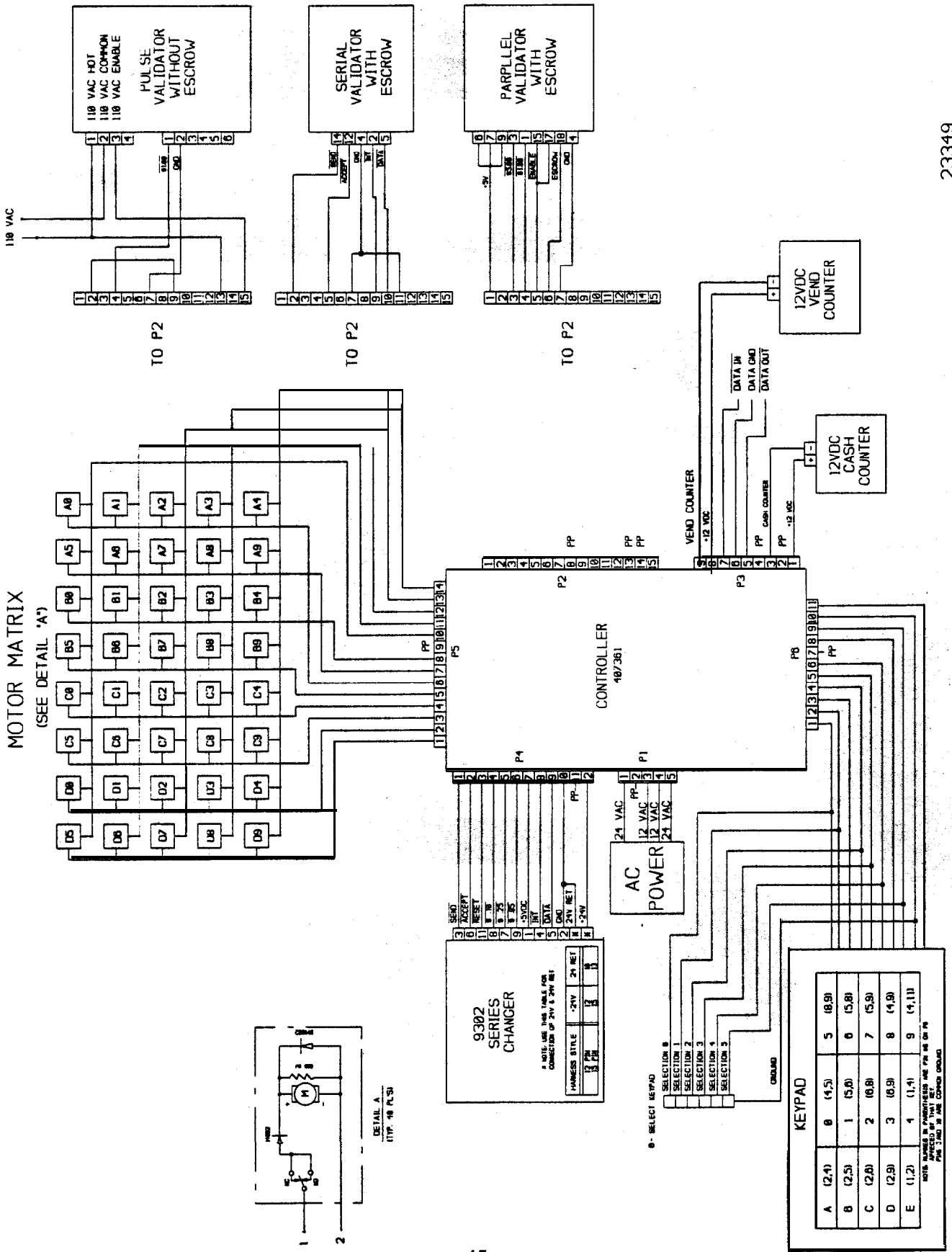

23349



**Polyvend**<sup>®</sup>  
INC.

700 South German Lane  
Conway, Arkansas 72032 USA  
(501) 327-1301